

Efficient Computation of Causal Behavioural Profiles using Structural Decomposition

Matthias Weidlich¹, Artem Polyvyanyy¹, Jan Mendling², and Mathias Weske¹

¹ Hasso Plattner Institute at the University of Potsdam, Germany
(Matthias.Weidlich,Artem.Polyvyanyy,Mathias.Weske)@hpi.uni-potsdam.de

² Humboldt-Universität zu Berlin, Germany
Jan.Mendling@wiwi.hu-berlin.de

Abstract. Identification of behavioural contradictions is an important aspect of software engineering, in particular for checking the consistency between a business process model used as system specification and a corresponding workflow model used as implementation. In this paper, we propose causal behavioural profiles as the basis for a consistency notion, which capture essential behavioural information, such as concurrency, exclusiveness, and causality between pairs of activities. Existing notions of behavioural equivalence, such as bisimulation and trace equivalence, might also be applied as consistency notions. Still, they are exponential in computation. Our novel concept of causal behavioural profiles provides a weaker behavioural consistency notion that can be computed efficiently using structural decomposition techniques for sound free-choice workflow systems if unstructured net fragments are acyclic or can be traced back to S- or T-nets.

1 Introduction

Process modelling has recently become one of the most extensively used approaches for capturing business requirements [1]. These requirements are typically refined and modified in an engineering process, resulting in a workflow model and software artefacts. A workflow model often defines activities of the business process model in more detail, neglects steps that are or do not need to be supported by the system, or adjusts behaviour to the specifics of the workflow system. This raises the question to which degree a process model used as specification and a workflow model used as implementation are behaviourally consistent.

Fig. 1 illustrates this problem. Model (a) assumes a business perspective, whereas (b) shows the workflow implementation of the process. Activities (or sets thereof) that correspond to each other are connected by dash-dotted lines. For this paper, we assume that such correspondences are given. They may stem from a system analyst inspecting the models or from automatic matching. Recently, techniques including structural analysis and natural language processing to automatically identify such correspondences have been introduced for the domain of business process models [2,3]. Moreover, techniques know from the area of

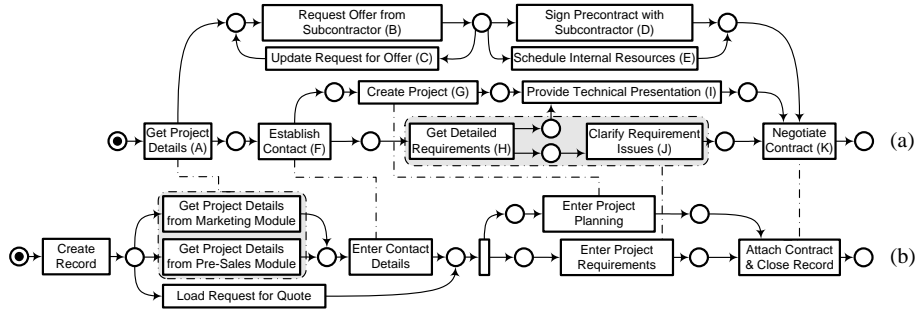

Fig. 1. Example of two Petri net process models, (a) focussing on the business perspective, (b) depicting the workflow implementation

schema matching [4] might also be exploited as activities might be regarded as elements of a process model schema.

In order to reason about the relation between two process models, existing notions of behavioural equivalence might be used as a consistency measure. For instance, bisimulation and trace equivalence assume the set of all traces or the branching structure as essential behavioural characteristics that have to be preserved. However, these notions are computationally hard [5], which is particularly a problem for process models including many activities. Furthermore, these notions only provide information whether behaviour is equivalent or not, but do not describe how strong a deviation is in case of a mismatch.

In this paper, we argue that for the use case of comparing business process models and workflow models, a criterion of behavioural equivalence might be weakened in order to compensate for computational efficiency. We define the notion of a *causal behavioural profile*, which includes dependencies in terms of concurrency, exclusiveness, or causality between pairs of activities. It is computed efficiently using structural decomposition techniques for sound free-choice workflow systems if unstructured net fragments are acyclic or can be traced back to S- or T-nets. We also illustrate how these profiles form the basis of a consistency notion that is weaker than existing notions of behavioural equivalence.

This paper is structured accordingly. Section 2 introduces our formal framework. Causal behavioural profiles are defined in Section 3. Section 4 elaborates on graph decomposition and introduces their application to workflow nets. Their application for computing causal behavioural profiles along with experimental results is presented in Section 5. Finally, Section 6 reviews related work, before Section 7 concludes the paper.

2 Preliminaries

We use workflow (WF-) systems [6] as our formal grounding, a class of Petri nets used for process modelling and analysis. Note that Petri net based formalisations have been presented for (parts of) common process modelling languages, such as BPEL, EPCs, and UML (e.g., [7,8,9]). Based on [6,10], we recall basic definitions.

Definition 1 (WF-net Syntax).

- A *net* is a tuple $N = (P, T, F)$ with P and T as finite disjoint sets of places and transitions, and $F \subseteq (P \times T) \cup (T \times P)$ as the flow relation. We write $X = (P \cup T)$ for all nodes. The transitive closure of F is denoted by F^+ .
- For a node $x \in X$, $\bullet x := \{y \in X \mid (y, x) \in F\}$, $x \bullet := \{y \in X \mid (x, y) \in F\}$.
- A tuple $N' = (P', T', F')$ is a *subnet* for a net $N = (P, T, F)$, if $P' \subseteq P$, $T' \subseteq T$, and $F' = F \cap ((P' \times T') \cup (T' \times P'))$. A subnet is *partial*, if $F' \subseteq F \cap ((P' \times T') \cup (T' \times P'))$.
- A net N is a *T-net*, if $\forall p \in P [|\bullet p| = 1 = |p \bullet|]$, and an *S-net*, if $\forall t \in T [|\bullet t| = 1 = |t \bullet|]$.
- A net N is *free-choice*, iff $\forall p \in P$ with $|p \bullet| > 1$ holds $\bullet(p \bullet) = \{p\}$.
- A *path* is a non-empty sequence x_1, \dots, x_k of nodes, $k > 1$, denoted by $\pi_N(x_1, x_k)$, which satisfies $(x_1, x_2), \dots, (x_{k-1}, x_k) \in F$. We write $x_i \in \pi_N$, if x_i is part of the path π_N . A *subpath* π'_N of a path π_N is a subsequence that is itself a path. A path $\pi_N(x_1, x_k)$ is a *circuit*, if $(x_k, x_1) \in F$ and no node occurs more than once in the path.
- For a net $N = (P, T, F)$ and a partial subnet N' a path $\pi_N(x_1, x_k)$ ($k > 1$ and all x_i are distinct) of N is a *handle* of N' , iff $\pi_N \cap (P' \cup T') = \{x_1, x_k\}$.
- For a net $N = (P, T, F)$ and two partial subnets N', N'' a path $\pi_N(x_1, x_k)$ ($k > 1$ and all x_i are distinct) of N is a *bridge* from N' to N'' , iff $\pi_N \cap (P' \cup T') = \{x_1\}$ and $\pi_N \cap (P'' \cup T'') = \{x_k\}$.
- A *workflow (WF-) net* is a net $N = (P, T, F)$, such that there is exactly one place $i \in P$ with $\bullet i = \emptyset$, exactly one place $o \in P$ with $o \bullet = \emptyset$, and $\forall x \in X [iF^+x \wedge xF^+o]$.

Note that we speak of *PP-, TT-, PT-, TP-* handles and bridges, depending on the type (place or transition, respectively) of the initial and the final node of the respective path. Further on, we define semantics for WF-nets according to [6].

Definition 2 (WF-net Semantics). Let $N = (P, T, F)$ be a WF-net with initial place i and final place o .

- $M : P \mapsto \mathbb{N}$ is a *marking* of N , \mathbb{M} denotes all markings of N . $M_i = [i]$ is the initial, $M_o = [o]$ the final marking, while $M(p)$ returns the number of tokens in p , if $p \in \text{dom}(M)$.
- For any transition $t \in T$ and any marking $M \in \mathbb{M}$, t is *enabled* in M , denoted by $(N, M)[t]$, iff $\forall p \in \bullet t [M(p) \geq 1]$. Marking M' is reached from M in N by *firing* of t , denoted by $(N, M)[t](N, M')$, such that $M' = M - \bullet t + t \bullet$.
- A *firing sequence* of length $n \in \mathbb{N}$ is a function $\sigma : \{0, \dots, n-1\} \mapsto T$. For $\sigma = \{(0, t_x), \dots, (n-1, t_y)\}$, we also write $\sigma = t_0, \dots, t_{n-1}$.
- For any two markings $M, M' \in \mathbb{M}$, M' is *reachable* from M in N , denoted by $M' \in [N, M_i]$, if there exists a firing sequence σ leading from M to M' .

Given a (free-choice, S-, T-) WF-net N with M_i as its initial marking, the tuple $S = (N, M_i)$ is a (free-choice, S-, T-) *WF-system*. Without stating it explicitly, we assume a net of a system to be defined as $N = (P, T, F)$. We also recall the *soundness* criterion, which requires WF-systems (1) to always terminate, and (2) to have no dead transitions (proper termination is implied for WF-systems) [11].

Definition 3 (Liveness, Boundness, Soundness).

- A WF-system (N, M_i) is *live*, if for every reachable marking $M \in [N, M_i)$ and $t \in T$, there is a marking $M' \in [N, M)$ such that $(N, M')[t]$.
- A WF-system (N, M_i) is *bounded*, iff the set $[N, M_i)$ is finite.
- A WF-system (N, M_i) with $N = (P, T, F)$ is *sound*, iff the short-circuit system (N', M_i) , $N' = (P, T \cup \{t_c\}, F \cup \{(o, t_c), (t_c, i)\})$, is live and bounded.

3 The Notion of a Causal Behavioural Profile

This section introduces causal behavioural profiles. They are based on the notion of behavioural profiles, which we recall in Section 3.1. We introduced these profiles in an earlier work [12] to reason on execution ordering constraints only. Thus, optionality of transition execution or causality between transitions is not captured. These aspects are addressed by the novel concept of a causal behavioural profile introduced in Section 3.2. Subsequently, Section 3.3 discusses our concepts with respect to their relation to existing behavioural models defined for Petri nets. Finally, we discuss the application of causal behavioural profiles for consistency checking in Section 3.4.

3.1 Execution Order Constraints: The Behavioural Profile

Behavioural profiles aim at capturing behavioural aspects in terms of order constraints of a process in a fine-grained manner [12]. They are grounded on the set of possible firing sequences of a WF-system and the notion of *weak order*.

Definition 4 (Weak Order). Let (N, M_i) be a WF-system. A pair (x, y) is in the *weak order relation* $\succ \subseteq T \times T$, iff there exists a firing sequence $\sigma = t_1, \dots, t_n$ with $(N, M_i)[\sigma]$, $j \in \{1, \dots, n-1\}$, $j < k \leq n$, for which holds $t_j = x$ and $t_k = y$.

Thus, two transitions t_1, t_2 are in weak order, if there exists a firing sequence reachable from the initial marking in which t_1 occurs before t_2 . Depending on how two activities of a process model are related by weak order, we define three relations forming the behavioural profile.

Definition 5 (Behavioural Profile). Let (N, M_i) be a WF-system. A pair $(x, y) \in (T \times T)$ is in at most one of the following relations:

- The *strict order relation* \rightsquigarrow , if $x \succ y$ and $y \not\succeq x$.
- The *exclusiveness relation* $+$, if $x \not\succeq y$ and $y \not\succeq x$.
- The *observation concurrency relation* \parallel , if $x \succ y$ and $y \succ x$.

Given a set $T' \subseteq T$, the set of all relations $BP_{T'} = \{\rightsquigarrow, +, \parallel\}$ defined over $T' \times T'$ is the *behavioural profile* of (N, M_i) for T' .

Computing the behavioural profile for all transitions of the system (a) in Fig. 1, for instance, it holds $C \rightsquigarrow E$ as there exists no firing sequence, such that E occurs before C . However, strict order does not imply the actual occurrence. That is, there are firing sequences containing only one of the two transitions, or

even none of them. $D + E$ as both transitions will never occur in a single firing sequence and $B||G$ as both transitions can occur in any order. Note that the three relations are mutually exclusive and (together with *reversed* strict order) partition the Cartesian product of transitions over which they are defined [12]. With respect to itself, a transition is either in the exclusive relation (if it can occur at most once, e.g., $D + D$) or in the observation concurrency relation (if it can occur more than once, e.g., $B||B$).

3.2 Occurrence Constraints: The Causal Behavioural Profile

Behavioural profiles as introduced above relate pairs of transitions according to their *order* of potential occurrence. While an analysis of order constraints might be sufficient for certain use cases, a more extensive analysis is needed for validating a workflow implementation against a process model specification. Thus, aspects that go beyond order of occurrences, such as optionality and causality, have to be taken into account.

Optionality of a transition is given, if there is a firing sequence leading from the initial to the final marking of the system that does not contain the transition. Optionality might also be lifted from single transitions to sets of transitions. A set of transitions is considered to be jointly optional, if any firing sequence from the initial to the final marking contains all or none of the transitions. As illustrated by Fig. 2(a) and Fig. 2(b) this property cannot be derived from the knowledge about optionality of single transitions. In both systems, B and C are optional, but only in Fig. 2(b) the set $\{B, C\}$ is optional.

Closely related to optionality is *causality*, which requires that one transition can only occur after the occurrence of another transition. Thus, causality comprises two aspects, a certain *order* of occurrences and a *causal coupling* of occurrences. While the former is addressed by the behavioural profile in terms of the strict order relation, the latter is not captured. For instance, B is a cause of C in Fig. 2(b), but not in Fig. 2(a). Note that two observation concurrent transitions cannot show causality according to our definition. For both systems in Fig. 3, it holds $B||C$, as

there is no distinct order relation between *all* occurrences of the two transitions. Thus, observation concurrency might be interpreted as the absence of any strict dependency regarding order of occurrence. Therefore, it is reasonable to define causality also as a dependency between *all* occurrences of two transitions, instead of considering causal dependencies between *single* occurrences of transitions (as, e.g., the *response/leads-to* dependency in [13]). Thus, there is no causality

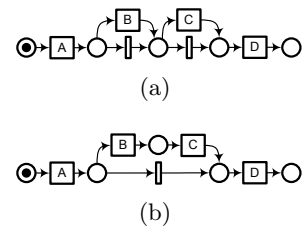

Fig. 2. Optionality

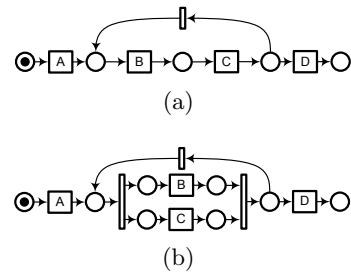

Fig. 3. No causality for transitions (B, C) in a cycle

between B and C in either system in Fig. 3, as both transitions are not ordered regarding their potential occurrence.

In order to cope with the aforementioned aspects, we introduce the co-occurrence relation and the causal behavioural profile. Two transitions are co-occurring, if any firing sequence from the initial to the final marking that contains the first transition contains also the second transition.

Definition 6 (Causal Behavioural Profile). Let (N, M_i) be a WF-system.

- A pair $(x, y) \in (T \times T)$ is in the *co-occurrence relation* \gg , if for all firing sequences σ with $(N, M_i)[\sigma](N, M_o)$, it holds $x \in \sigma \Rightarrow y \in \sigma$.
- Given a set $T' \subseteq T$, the set of all relations $CBP_{T'} = \{\rightsquigarrow, +, ||, \gg\}$ defined over $T' \times T'$ is the *causal behavioural profile* of (N, M_i) for T' .

Trivially, it holds $t \gg t$ for all $t \in T$. We derive optionality and causality as follows. A single transition $t \in T$ is optional, if $t_i \rightsquigarrow t$ for some $t_i \in i\bullet$ with i as the initial place. A set $T_1 \subseteq T$ of transitions is optional, if all transitions themselves are optional and they are pairwise co-occurring to each other $((T_1 \times T_1) \subseteq \gg)$.

Further on, a transition $t_1 \in T$ is a cause of $t_2 \in T$, if they are in strict order $(t_1 \rightsquigarrow t_2)$ and occurrence of the second implies occurrence of the first $(t_2 \gg t_1)$. Note that, in contrast to the behavioural profile, the *causal* behavioural profile differs for both systems in Fig. 2.

3.3 Relation to Existing Behavioural Models

There is a large body of research on behavioural relations for formal models specifying dynamic systems in general, and for Petri nets in particular. Focussing on constraints regarding the order of occurrence, the relations proposed in [14] for workflow mining are close to our relations, yet different. We base our definitions on the notion of an *indirect* weak order dependency, whereas the relations in [14] are grounded on a *direct* sequential order. As a result, for instance, the notion of exclusiveness is restricted to ‘*pairs of transitions that never follow each other directly*’ [14], whereas we capture exclusiveness for transitions that might occur at different stages of a firing sequence.

Obviously, the well-known notions of *conflicting* and *concurrent* transitions are related to our *observed* relations as well. For our case of sound free-choice WF-systems, two transitions in conflict will be exclusive or observation concurrent in the behavioural profile, depending on whether or not they are part of a common control flow cycle, cf., [12]. Similarly, all transitions that are enabled concurrently in some reachable marking (cf., the concurrency relation computed in [15]) are observation concurrent in the behavioural profile.

In order to cope with concurrency and the interleaving problem, the *unfolding* of a Petri net (or the prefix of the unfolding, respectively) might be exploited for behaviour analysis [16,17]. That is, a *true concurrent* model is created in which a transition (i.e., an *event*) corresponds to a certain *occurrence* of a transition in the original net. Based thereon, events can be related as being in a *weak causal predecessor*, *conflict*, or *concurrency* relation. While these relations resemble

the relations of our casual behavioural profile, they are defined for events, i.e., transition occurrences, instead of transitions. Thus, we might derive our relations by lifting these relations to the level of transitions again. For instance, if all events representing two transitions are in conflict in the (potentially infinite) unfolding, both transitions are exclusive according to the behavioural profile. However, an algorithm describing the derivation of causal behavioural profiles from the prefix of an unfolding is beyond the scope of this paper. Usage of unfoldings is also inappropriate w.r.t. the class of systems we address in this paper, as the construction of unfoldings is computationally much harder than the approach introduced in the remainder of this paper.

With respect to common notions of behavioural equivalence, we see that two WF-systems with equal causal profiles are not necessarily trace equivalent. For instance, both systems in Fig. 3 have the same causal profile, whereas they are not trace equivalent. Evidently, the same holds true for bisimulation equivalences, as the profile neglects the branching structure of a system. However, it is easy to see that trace equivalence of two WF-systems implies equivalence of their causal behavioural profiles for all transitions, as all behavioural relations formulate statements about the existence of firing sequences.

3.4 Application of Causal Behavioural Profiles

We motivated the definition of causal behavioural profiles with the need for a notion of behavioural consistency that enables analysis of related process models in an efficient manner. Under the assumption of an alignment relation between transitions of two WF-systems, we define a consistency metric as follows.

Definition 7 (Consistency Metric). Let (N_1, M_{i_1}) and (N_2, M_{i_2}) be two WF-systems and $\sim \subseteq T_1 \times T_2$ a correspondence relation with $\sim \neq \emptyset$.

- The set $T_1^\sim = \{t_1 \in T_1 \mid \exists t_2 \in T_2 [t_1 \sim t_2]\}$ contains all *aligned transitions* of (N_1, M_{i_1}) . T_2^\sim is defined analogously.
- With \mathcal{R}_1 and \mathcal{R}_2 as the relations of the causal behavioural profile for the WF-systems, the set $CT_1^\sim \subseteq (T_1^\sim \times T_1^\sim)$ contains all *consistent transition pairs* (t_x, t_y) , such that
 - if $t_x = t_y$, then $\forall t_s \in T_2^\sim$ with $t_x \sim t_s$ it holds $t_x \mathcal{R}_1 t_x \Rightarrow t_s \mathcal{R}_2 t_s$,
 - if $t_x \neq t_y$, then $\forall t_s, t_t \in T_2^\sim$ with $t_s \neq t_t$, $t_x \sim t_s$, and $t_y \sim t_t$ it holds either $t_x \mathcal{R}_1 t_y \Rightarrow t_s \mathcal{R}_2 t_t$ or $t_x \sim t_t$ and $t_y \sim t_s$.

The set CT_2^\sim is defined analogously.

- The *degree of consistency* of \sim is defined as $\mathcal{D}^\sim = \frac{|CT_1^\sim| + |CT_2^\sim|}{|(T_1^\sim \times T_1^\sim)| + |(T_2^\sim \times T_2^\sim)|}$.

The general idea behind this metric can be summarised as follows. For each pair of transitions, for which there are corresponding transitions in the other model, we check whether they share the same constraints. Since there can be complex 1:n correspondences as in Fig. 1, we have to count these correspondences from the perspective of each model. Applying this metric to the scenario in Fig. 1, we see that the order of potential occurrence is preserved for all aligned transitions. However, transition (A) is mandatory in model (a), whereas its counterparts

are optional in model (b). Consequently, causality between transition (A) and, for instance, transition (K) is not preserved in model (b) either, which is taken into account in the causal behavioural profile. For our example, the degree of consistency is $\mathcal{D}^\sim = \frac{28+27}{36+36} \approx 0.76$, as both models (a) and (b) contain six transitions with correspondences yielding 36 transition pairs in the profile, while the profile relations are preserved for 28 (or 27, respectively) pairs.

For our proposal of assessing the consistency between business process models and their implementation as a workflow model, we got positive feedback from process analysts. Currently, we are also evaluating the results of an empirical study that relates our consistency metric to the consistency perception of process experts in a broader setting. Here, preliminary findings confirm a good approximation of perceived consistency by our metric. Clearly, there is a need for a multitude of consistency metrics in order to be able to graduate consistency requirements for a concrete setting. Nevertheless, the metric nature and efficient computation methods have to be seen as core requirements on such notions.

It is also worth to mention that we already showed how behavioural profiles can be applied to support change propagation between related process models [18].

4 Graph Decomposition Techniques for WF-Systems

First, Section 4.1 introduces the Refined Process Structure Tree (RPST), a structural decomposition technique for workflow graphs. Second, Section 4.2 enriches the RPST for WF-systems with behavioural annotations.

4.1 The Refined Process Structure Tree

The RPST [19,20] is a technique for detecting the structure of a workflow graph. A workflow graph can be parsed into a hierarchy of *fragments* with a single entry and a single exit, such that the RPST is a containment hierarchy of *canonical* fragments of the graph. The RPST is unique for a given workflow graph and can be computed in linear time [19,20]. Although the RPST has been introduced for workflow graphs, the technique can be applied to other graph based behavioural models such as WF-systems in a straight-forward manner. Basic terms of the RPST are defined for WF-nets as follows.

Definition 8 (Connected, Edges, Entry, Exit, Canonical Fragment).

Let $N = (P, T, F)$ be a WF-net with initial place i and final place o .

- A net $N = (P, T, F)$ is *connected*, if $\forall x \in X [iF^+x \wedge xF^+o]$.
- For a node $x \in X$ of a net $N = (P, T, F)$, $in_N(x) = \{(n, x) \mid n \in \bullet x\}$ are its *incoming edges* and $out_N(x) = \{(x, n) \mid n \in x\bullet\}$ are its *outgoing edges*.
- A node $x \in X'$ of a connected subnet $N' = (P', T', F')$ of a net N is a *boundary node*, if $\exists e \in in_N(x) \cup out_N(x) [e \notin F']$. If x is a boundary node, it is an *entry* of N' , if $in_N(x) \cap F' = \emptyset$ or $out_N(x) \subseteq F'$, or an *exit* of N' , if $out_N(x) \cap F' = \emptyset$ or $in_N(x) \subseteq F'$.
- Any connected subnet ω of N , is a *fragment*, if it has exactly two boundary nodes, one entry and one exit denoted by ω_{\triangleleft} and ω_{\triangleright} , respectively.

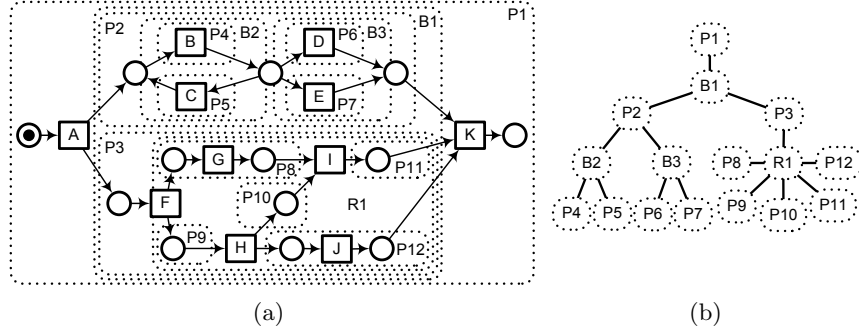

Fig. 4. (a) A WF-system and its canonical fragments, (b) the RPST of (a)

- A fragment is *place bordered* if its boundary nodes are places.
- A fragment is *transition bordered* if its boundary nodes are transitions.
- A fragment $\omega = (P_\omega, T_\omega, F_\omega)$ is *canonical* in a set of fragments Ω of N , iff $\forall \gamma = (P_\gamma, T_\gamma, F_\gamma) \in \Omega [\omega \neq \gamma \Rightarrow (F_\omega \cap F_\gamma = \emptyset) \vee (F_\omega \subset F_\gamma) \vee (F_\gamma \subset F_\omega)]$.

Fig. 4 exemplifies the RPST for the WF-system from Fig. 1(a). Fig. 4(a) illustrates its canonical fragments, each of them formed by a set of edges, together with incident nodes, enclosed in or intersecting the region with a dotted border. Fig. 4(b) provides an alternative view, where each node represents a canonical fragment and edges hint at containment relation of fragments. Observe that one obtains a tree structure—the RPST. For instance, fragment $B1$ has two boundary transitions: entry A and exit K , is contained in fragment $P1$, and contains fragments $P2$ and $P3$.

If the RPST is computed for a *normalized* workflow graph, i.e., a workflow graph that does not contain nodes with multiple incoming and multiple outgoing edges, each canonical fragment can be classified to one out of four structural classes [20,21]: A *trivial* (T) fragment consists of a single edge. A *polygon* (P) represents a sequence of nodes (fragments) of an arbitrary length. A *bond* (B) stands for a collection of fragments that share common boundary nodes. Any other fragment is a *rigid* (R). Note that we use fragment names that hint at their structural class, e.g., $R1$ is a rigid fragment. Note that every workflow graph can be normalized by performing a node-splitting pre-processing step. The pre-processing rules for WF-nets are given in Fig. 5. Here, the second rule normalizing a transition, avoids duplication of the respective transition. The example WF-system in Fig. 4(a) is already normalized.

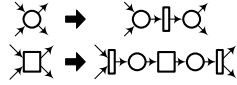

Fig. 5. Node-splitting

4.2 An Annotated RPST: The WF-Tree

The structural patterns derived by the RPST can be related to behavioural properties of the underlying WF-system. In this section, we concretise RPST fragments by annotating them with behavioural characteristics. We refer to the containment hierarchy of annotated canonical fragments of a WF-system as the RPST with behavioural annotations, or *WF-tree* for short. The WF-tree is

defined for sound free-choice WF-systems. It is well-known that the free-choice and soundness properties are required to derive behavioural statements from the structure of a system, as both together imply a tight coupling of syntax and semantics (cf., [22,23]).

Definition 9 (WF-Tree). Let (N, M_i) be a sound free-choice WF-system. The RPST with behavioural annotations, the *WF-Tree* of N , is a tuple $\mathcal{T}_N = (\Omega, \chi, t, b)$, where:

- Ω is a set of all canonical fragments of N ,
- $\chi : \Omega \rightarrow \mathcal{P}(\Omega)$ is a function that assigns to fragment its child fragments,
- $t : \Omega \rightarrow \{T, P, B, R\}$ is a function that assigns a type to a fragment,
- $b : \Omega_B \rightarrow \{B_\circ, B_\diamond, L\}$ is a partial function that assigns a refined type to a bond fragment, where B_\circ , B_\diamond , and L types stand for place bordered, transition bordered, and loop bonds, respectively.

Further on, we define auxiliary concepts for the WF-tree.

Definition 10 (Parent, Child, Root, Ancestor, Descendant, LCA, Path). Let $\mathcal{T}_N = (\Omega, \chi, t, b)$ be the WF-tree.

- For any fragment $\omega \in \Omega$, ω is a *parent* of γ and γ is a *child* of ω , if $\gamma \in \chi(\omega)$. By χ^+ we denote the transitive closure of χ .
- The fragment $\omega \in \Omega$ is a *root* of \mathcal{T} , denoted by ω_r , if it has no parent.
- The partial function $\rho : \Omega \setminus \{\omega_r\} \rightarrow \Omega$ assigns parents to fragments.
- For any fragment $\omega \in \Omega$, ω is an *ancestor* of ϑ and ϑ is a *descendant* of ω , if $\vartheta \in \chi^+(\omega)$.
- For any two fragments $\{\omega, \gamma\} \in \Omega$ their *lowest common ancestor* (LCA), denoted by $lca(\omega, \gamma)$, is the shared ancestor of ω and γ that is located farthest from the root of the WF-tree. By definition, $lca(\omega, \omega) = \omega$.
- For any fragment $\omega_0 \in \Omega$ and its descendant $\omega_n \in \Omega$, a *downward path* from ω_0 to ω_n , denoted by $\pi_{\mathcal{T}}(\omega_0, \omega_n)$, is a sequence $(\omega_0, \omega_1, \dots, \omega_n)$, such that ω_i is a parent of ω_{i+1} for all $i \in \mathbb{N}_0$. In addition, $\pi_{\mathcal{T}}(\omega_0, \omega_n, i) = \omega_i$ and $\pi_{\mathcal{T}}\{\omega_0, \omega_n\}$ is a set which contains all fragments of $\pi_{\mathcal{T}}(\omega_0, \omega_n)$.

Fig. 6 shows the WF-tree of the WF-system from Fig. 4(a). Note that trivial fragments are not visualised. The WF-tree is isomorphic to the RPST of the WF-system, cf., Fig. 4(b). Given the RPST, adding the behavioural annotation is a trivial task for most fragments, except of the following cases: A bond fragment $\gamma = (P_\gamma, T_\gamma, F_\gamma) \in \text{dom}(b)$ of $\mathcal{T}_N = (\Omega, \chi, t, b)$ is assigned the L type, if $\gamma_\triangleleft = \omega_\triangleright$ with ω being a child of γ . Otherwise, $b(\gamma) = B_\circ$ if $\gamma_\triangleleft \in P_\gamma$, or $b(\gamma) = B_\diamond$ if $\gamma_\triangleleft \in T_\gamma$.

Children of a polygon fragment are arranged with respect to their execution order. A partial function $order : \Omega' \rightarrow \mathbb{N}_0$, $\Omega' = \{\omega \in \Omega \setminus \{\omega_r\} \mid t(\rho(\omega)) = P\}$ assigns to children of polygon fragments their respective order positions; $order(\omega) = 0$, if $\omega_\triangleleft = \gamma_\triangleleft$ with $\gamma = \rho(\omega)$ being the parent, and $order(\omega) = i$, $i \in \mathbb{N}$, if $\omega_\triangleleft = \vartheta_\triangleright$

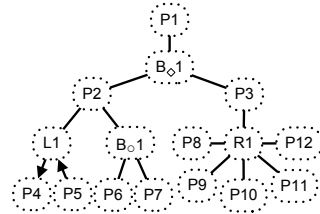

Fig. 6. The WF-tree

for some $\vartheta \in \Omega$, such that $order(\vartheta) = i - 1$. Observe that the orders of two nodes are only comparable if they share a common parent. For instance, in Fig. 6, $order(L1) = 1$ and $order(B_{\circ}1) = 2$. This means that fragment $L1$ is always executed before fragment $B_{\circ}1$ inside of polygon $P2$. The layout of child fragments of polygon fragments hints at their order relations.

Children of a loop fragment are classified as *forward* (\Rightarrow) or *backward* (\Leftarrow). A partial function $\ell : \Omega'' \rightarrow \{\Leftarrow, \Rightarrow\}$ with $\Omega'' = \{\omega \in \Omega \setminus \{\omega_r\} \mid b(\rho(\omega)) = L\}$ assigns an orientation to children of loop fragments. $\ell(\omega) = \Rightarrow$ if $\omega_{\triangleleft} = \gamma_{\triangleleft}$ with $\gamma = \rho(\omega)$, otherwise $\ell(\omega) = \Leftarrow$. In Fig. 6, $P4$ and $P5$ are forward and backward fragments, respectively, which is visually illustrated by the direction of edges in the WF-tree.

In the following, we introduce two lemmas that prove the completeness of the codomain of function b of the WF-tree. We show that a bond fragment is either place or transition bordered, and that each loop fragment is place bordered. Note that a rigid fragment that is bordered with a place and a transition can still be free-choice and sound (see [24] for an example).

Lemma 1. *Let $\mathcal{T}_N = (\Omega, \chi, t, b)$ be the WF-tree of a sound free-choice WF-system (N, M_i) , $N = (P, T, F)$. No bond fragment $\omega \in \Omega$, $t(\omega) = B$, has $\{p, t\}$ boundary nodes, where $p \in P$ and $t \in T$.*

Proof. Assume ω is a bond fragment with $\{p, t\}$ boundary nodes. There exists a circuit Γ in N that contains $\{p, t\}$. Let Γ_{ω} be a subpath of Γ inside ω . There exists a child fragment γ of ω that contains Γ_{ω} . A bond fragment has $k \geq 2$ child fragments, cf., [20,21]. Let ϑ be a child of ω , $\vartheta \neq \gamma$. We distinguish two cases:

- Let H be a path from p to t contained in ϑ . H is a PT-handle of Γ . In a live and bounded free-choice system, H is bridged to Γ_{ω} through a TP-bridge K , cf., Proposition 4.2 in [25]. This implies that $\vartheta = \gamma$; otherwise bond fragment ω contains path K that is not inside of a single child fragment, cf., [21,20].
- Let H be a path from t to p contained in ϑ . H is a TP-handle of Γ . In a live and bounded free-choice system, no circuit has TP-handles, cf., Proposition 4.1 in [25]. Thus, (N, M_i) is not a sound free-choice WF-system.

Therefore, ω either has a single child fragment, in which case ω is not a bond fragment, or (N, M_i) is not a sound free-choice WF-system. \square

Lemma 2. *Let $\mathcal{T}_N = (\Omega, \chi, t, b)$ be the WF-tree of a sound free-choice WF-system, (N, M_i) , $N = (P, T, F)$. A loop fragment $\omega = (P_{\omega}, T_{\omega}, F_{\omega}) \in \Omega$, $b(\omega) = L$, is place bordered, i.e., $\{\omega_{\triangleleft}, \omega_{\triangleright}\} \in P$.*

Proof. Because of Lemma 1, ω is either place or transition bordered. Assume ω is transition bordered. There exists place p such that $p \in \bullet\omega_{\triangleleft} \cap P_{\omega}$, $M_i(p) = 0$. Transition ω_{\triangleleft} is enabled if there exists a marking $M \in [(N, M_i)]$ with $M(p) > 0$. Since ω is a connected subnet, for all $t \in T_{\omega} \setminus \{\omega_{\triangleleft}, \omega_{\triangleright}\}$ all edges are in ω , i.e., $(in_N(t) \cup out_N(t)) \subseteq F_{\omega}$. Thus, every path from i to p visits ω_{\triangleleft} . Thus, $M(p) > 0$ if ω_{\triangleleft} has fired, was enabled, before. We reached a contradiction. Transition ω_{\triangleleft} is never enabled and N is not live, and hence, not sound. Since any loop fragment is not transition bordered, it is place bordered (Lemma 1). \square

For sound free-choice WF-systems, the WF-tree can be derived efficiently.

Corollary 1. *The following problem can be solved in linear time.
Given a sound free-choice WF-system, to compute its WF-tree.*

Proof. Given a workflow graph, its RPST can be computed in time linear to the number of edges of the graph [19,20]. The number of canonical fragments in the RPST is linear to the number of edges in the workflow graph [20,26,27]. Given the RPST of a WF-system, we iterate over all bond fragments and assign the behavioural annotations. Here, it suffices to check the type of the entry node, either a place or transition, and to determine whether the entry is also the exit of the parent fragment. That can be decided in constant time for each fragment. Finally, child fragments of a polygon can be ordered in linear time. We introduce a hash function that returns a child fragment with the given node as an entry and iterate over the children of the polygon. \square

5 Efficient Computation of Causal Behavioural Profiles

This section shows how a WF-tree is applied to compute the causal behavioural profile. Section 5.1 introduces the approach for transition pairs that do not require analysis of rigid fragments. Afterwards, we discuss analysis of rigid fragments in Section 5.2 and present experimental performance results in Section 5.3.

5.1 Computation without Analysis of Rigid Fragments

For the computation of the causal behavioural profile for a pair of transitions, we assume that each transition has one incoming and one outgoing flow arc. If this is not the case, we apply the pre-processing illustrated in Fig. 5, which preserves the behaviour of the system (cf., [28]) and, therefore, does not change the causal behavioural profile. Given a pre-processed WF-system (N, M_i) with $N = (P, T, F)$ and its WF-tree $\mathcal{T}_N = (\Omega, \chi, t, b)$, each transition $t \in T$ is a boundary node of at most two trivial fragments of \mathcal{T}_N . Thus, it suffices to show how the behavioural relations are determined for the entries of two trivial fragments.

Note that our computation is based on two elementary well-known properties of free-choice sound WF-systems. If (N, M_i) is free-choice and sound, it is also safe (cf., Lemma 1 in [23]), i.e., $\forall p \in P, M(p) < 2$ in all reachable markings. Thus, a single transition cannot be enabled concurrently with itself. In addition, if (N, M_i) is free-choice, the existence of a path $\pi_N(x, y)$ between two places x and y implies the existence of a firing sequence containing all transitions on $\pi_N(x, y)$ (cf., Lemma 4.2 in [22]).

Actually, the marking M_y that puts a token in y is required to be a home marking (a marking which is reachable from every marking reachable from the initial state). Soundness of a system (N, M_i) implies liveness of its short-circuit system (N', M_i) . Thus, all markings $M \in [N, M_i]$ are home markings in (N', M_i) and the property holds for all markings $M \in [N, M_i]$ in a sound free-choice system.

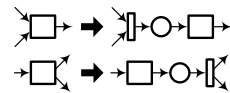

Fig. 7. Pre-processing

In the absence of rigid fragments on certain paths, we derive the behavioural profile as follows.

Proposition 1. Let $\mathcal{T}_N = (\Omega, \chi, t, b)$ be the WF-tree and $\alpha, \beta \in \Omega$ two trivial fragments. Let $\gamma = lca(\alpha, \beta)$ and $\forall \omega \in \pi_{\mathcal{T}}\{\omega_r, \gamma\} [t(\omega) \neq R]$.

1. If $\alpha = \beta$, then $\alpha_{\triangleleft} \parallel \beta_{\triangleleft}$, iff $\exists \omega \in \pi_{\mathcal{T}}\{\omega_r, \gamma\} [b(\omega) = L]$. Otherwise, $\alpha_{\triangleleft} + \beta_{\triangleleft}$.
2. If $\alpha \neq \beta$,
 - $\alpha_{\triangleleft} \rightsquigarrow \beta_{\triangleleft}$, iff (1) $t(\gamma) = P \wedge order(\pi_{\mathcal{T}}(\gamma, \alpha, 1)) < order(\pi_{\mathcal{T}}(\gamma, \beta, 1))$, and (2) $\forall \omega \in \pi_{\mathcal{T}}\{\omega_r, \gamma\} [b(\omega) \neq L]$.
 - $\alpha_{\triangleleft} + \beta_{\triangleleft}$, iff (1) $b(\gamma) = B_{\circ}$, and (2) $\forall \omega \in \pi_{\mathcal{T}}\{\omega_r, \gamma\} [b(\omega) \neq L]$.
 - $\alpha_{\triangleleft} \parallel \beta_{\triangleleft}$, iff (1) $b(\gamma) \in \{B_{\circ}, L\}$, or (2) $\exists \omega \in \pi_{\mathcal{T}}\{\omega_r, \gamma\} [b(\omega) = L]$.

Proof. Let \mathcal{T}_N , α , β , γ be defined as above, (N, M_i) the respective WF-system, and $\forall \omega \in \pi_{\mathcal{T}}\{\omega_r, \gamma\} [t(\omega) \neq R]$.

1. Let $\alpha = \beta$.
 - \Rightarrow Let $\alpha_{\triangleleft} \parallel \beta_{\triangleleft}$ and assume $\forall \omega \in \pi_{\mathcal{T}}\{\omega_r, \gamma\} [b(\omega) \neq L]$. Due to $\alpha = \beta$, also $\alpha_{\triangleleft} = \beta_{\triangleleft}$. Thus, we have $\alpha_{\triangleleft} \parallel \alpha_{\triangleleft}$. Due to safeness of (N, M_i) , $\alpha_{\triangleleft} \parallel \alpha_{\triangleleft}$ cannot be traced back to concurrent enabling of α_{\triangleleft} . According to Lemma 2 in [12], that implies $\alpha_{\triangleleft} F^+ \alpha_{\triangleleft}$. Control flow cycles are part of B (if the bond is a loop fragment) or R type fragments. Thus, there has to be a fragment ω , which is an ancestor of α and $t(\omega) = R$ or $b(\omega) = L$. As the LCA of α is $\gamma = \alpha$ by definition, this yields a contradiction with the assumptions.
 - \Leftarrow Let $\exists \omega \in \pi_{\mathcal{T}}\{\omega_r, \gamma\} [b(\omega) = L]$ and assume $\alpha_{\triangleleft} \not\parallel \beta_{\triangleleft}$. Since $\alpha = \beta$, we have $\alpha_{\triangleleft} = \beta_{\triangleleft}$. One of the ancestors of α is an B type fragment that is a loop. Thus, $\alpha_{\triangleleft} F^+ \alpha_{\triangleleft}$. Since (N, M_i) is safe, α_{\triangleleft} cannot be enabled concurrently with itself. Therefore, $\alpha_{\triangleleft} \parallel \alpha_{\triangleleft}$ due to Lemma 2 in [12].
2. Let $\alpha \neq \beta$.
 - \Rightarrow Let $\alpha_{\triangleleft} \rightsquigarrow \beta_{\triangleleft}$ and assume (1) $order(\pi_{\mathcal{T}}(\gamma, \alpha, 1)) > order(\pi_{\mathcal{T}}(\gamma, \beta, 1))$ or $t(\gamma) \neq P$, or (2) $\exists \omega \in \pi_{\mathcal{T}}\{\omega_r, \gamma\} [b(\omega) = L]$. According to Theorem 1 in [12], $\alpha_{\triangleleft} \rightsquigarrow \beta_{\triangleleft}$ implies $\alpha_{\triangleleft} F^+ \beta_{\triangleleft}$ and $\beta_{\triangleleft} \not F^+ \alpha_{\triangleleft}$. Thus, assumption (2) cannot hold as an L type fragment that is an ancestor of both, α and β , would imply $\beta_{\triangleleft} F^+ \alpha_{\triangleleft}$. The first part of assumption (1) cannot hold either: $b(\gamma) = L$ contradicts with the flow dependencies between α_{\triangleleft} and β_{\triangleleft} , while $t(\gamma) = R$, $t(\gamma) = B$ and $b(\gamma) \in \{B_{\circ}, B_{\circ}\}$, and $t(\gamma) = T$ (which would imply $\alpha = \beta$) disqualify due to our assumptions. Thus, $t(\gamma) = P$. Obviously, the order in a P type fragment coincidences with the flow dependencies, i.e., $\alpha_{\triangleleft} F^+ \beta_{\triangleleft}$ yields a contradiction with $order(\pi_{\mathcal{T}}(\gamma, \alpha, 1)) > order(\pi_{\mathcal{T}}(\gamma, \beta, 1))$.
 - Let $\alpha_{\triangleleft} + \beta_{\triangleleft}$ and assume (1) $b(\gamma) \neq B_{\circ}$ or (2) $\exists \omega \in \pi_{\mathcal{T}}\{\omega_r, \gamma\} [b(\omega) = L]$. According to Lemma 3 in [12], the former implies $\alpha_{\triangleleft} \not F^+ \beta_{\triangleleft}$ and $\beta_{\triangleleft} \not F^+ \alpha_{\triangleleft}$. That, in turn, implies that assumption (2) cannot hold and $\gamma \neq P$. Also $\gamma \neq R$ and $\gamma \neq T$ (which would imply $\alpha = \beta$) by our assumptions. Thus, $t(\gamma) = B$. As the flow dependencies preclude $b(\gamma) = L$, we assume $b(\gamma) = B_{\circ}$. Then, γ_{\triangleleft} is a transition. Due to soundness, there are two markings $M_1, M_2 \in [N, M_i]$, such that $(N, M_1)[\gamma_{\triangleleft}](N, M_2)$. As γ is an

ancestor of both, α and β , we know $\gamma_{\triangleleft} F^+ \alpha_{\triangleleft}$ and $\gamma_{\triangleleft} F^+ \beta_{\triangleleft}$. That implies that both transitions, α_{\triangleleft} and β_{\triangleleft} , might get enabled in a firing sequence starting in M_2 . That is not in line with $\alpha_{\triangleleft} + \beta_{\triangleleft}$. Thus, $b(\gamma) = B_{\circ}$, a contradiction with assumption (1).

Let $\alpha_{\triangleleft} \parallel \beta_{\triangleleft}$ and assume (1) $b(\gamma) = B_{\circ}$ and (2) $\forall \omega \in \pi_{\mathcal{T}}\{\omega_r, \gamma\} [b(\omega) \neq L]$. According to Lemma 2 in [12] $\alpha_{\triangleleft} \parallel \beta_{\triangleleft}$ implies concurrent enabling of a both transitions in a certain marking, or $\alpha_{\triangleleft} F^+ \beta_{\triangleleft}$ and $\beta_{\triangleleft} F^+ \alpha_{\triangleleft}$. The latter is not possible due to assumption (2). Thus, we assume concurrent enabling. Let $x \in \gamma_{\triangleleft} \bullet$ be a successor of γ_{\triangleleft} . γ is the LCA of α and β . Consequently, $x F^+ \alpha_{\triangleleft}$ implies $x \not F^{\times} \beta_{\triangleleft}$ and vice versa. Thus, concurrently enabling of α_{\triangleleft} and β_{\triangleleft} requires γ_{\triangleleft} to be a transition. That, in turn, is a contradiction with assumption (1).

\Leftarrow Let (1) $t(\gamma) = P \wedge \text{order}(\pi_{\mathcal{T}}(\gamma, \alpha, 1)) < \text{order}(\pi_{\mathcal{T}}(\gamma, \beta, 1))$, and (2) $\forall \omega \in \pi_{\mathcal{T}}\{\omega_r, \gamma\} [b(\omega) \neq L]$ and assume $\alpha_{\triangleleft} \not\prec \beta_{\triangleleft}$. From (1) and (2), we get $\alpha_{\triangleleft} F^+ \beta_{\triangleleft}$ and $\beta_{\triangleleft} \not F^{\times} \alpha_{\triangleleft}$. According to Theorem 1 in [12], this is equivalent to $\alpha_{\triangleleft} \rightsquigarrow \beta_{\triangleleft}$.

Let (1) $b(\gamma) = B_{\circ}$ and (2) $\forall \omega \in \pi_{\mathcal{T}}\{\omega_r, \gamma\} [b(\omega) \neq L]$, and assume $\alpha_{\triangleleft} \not\prec \beta_{\triangleleft}$. From (1) and (2), we get $\alpha_{\triangleleft} \not F^{\times} \beta_{\triangleleft}$ and $\beta_{\triangleleft} \not F^{\times} \alpha_{\triangleleft}$. Therefore, we assume that both transitions are enabled concurrently. Due to $b(\gamma) = B_{\circ}$, γ_{\triangleleft} is a place. Let $t \in \gamma_{\triangleleft} \bullet$ be a successor of γ_{\triangleleft} . Due to soundness, there are two markings $M_1, M_2 \in [N, M_i]$, such that $(N, M_1)[t](N, M_2)$. As γ is the LCA of both, we know that $t F^+ \alpha_{\triangleleft}$ implies $t \not F^{\times} \beta_{\triangleleft}$ and vice versa. Thus, any firing sequence starting in M_2 contains either α_{\triangleleft} , β_{\triangleleft} , or none of the two transitions. As γ is the parent of both, α and β , γ_{\triangleleft} is on every path from the initial place i to α_{\triangleleft} and β_{\triangleleft} . Therefore, there does not exist a firing sequence containing both transitions, which leads to $\alpha_{\triangleleft} + \beta_{\triangleleft}$.

Let (1) $b(\gamma) \in \{B_{\circ}, L\}$ or (2) $\exists \omega \in \pi_{\mathcal{T}}\{\omega_r, \gamma\} [b(\omega) = L]$, and assume $\alpha_{\triangleleft} \not\parallel \beta_{\triangleleft}$. From requirement (2), we get $\alpha_{\triangleleft} F^+ \beta_{\triangleleft}$ and $\beta_{\triangleleft} F^+ \alpha_{\triangleleft}$. According to Lemma 2 in [12] this is equivalent to $\alpha_{\triangleleft} \parallel \beta_{\triangleleft}$, which is not in line with our assumption. The same holds true for $b(\gamma) = L$. Consider $b(\gamma) = B_{\circ}$. Then, γ_{\triangleleft} is a transition. Let $p_1, p_2 \in \gamma_{\triangleleft} \bullet$ be two successors of γ_{\triangleleft} with $p_1 F^+ \alpha_{\triangleleft}$ and $p_2 F^+ \beta_{\triangleleft}$. The existence of these paths implies the existence of a firing sequence, i.e., α_{\triangleleft} and β_{\triangleleft} can get enabled concurrently. That, in turn, is equivalent to $\alpha_{\triangleleft} \parallel \beta_{\triangleleft}$ by Lemma 1 in [12] yielding a contradiction with our assumption. \square

For the derivation of the co-occurrence relation, we need an auxiliary lemma for the relation between (forwards and backwards) conflict-free paths and the co-occurrence relation. As usual, given a WF-net $N = (P, T, F)$ a path $\pi_N(x_1, x_k)$ is *forwards conflict-free*, iff $x_i \in P$ implies $|x_i \bullet| = 1$ for $1 \leq i < k$. The path $\pi_N(x_1, x_k)$ is *backwards conflict-free*, iff $x_i \in P$ implies $|\bullet x_i| = 1$ for $1 < i \leq k$.

Lemma 3. *For any two transitions x and y in a sound free-choice WF-system holds,*

- \circ *if there is a forwards conflict-free path from x to y , then $x \gg y$.*

- if there is a backwards conflict-free path from x to y , then $y \gg x$.

Proof. Let (N, M_i) be a sound free-choice WF-system and $x, y \in T$ two transitions.

- If $y \in (x\bullet)\bullet$ then every firing sequence σ containing x and ending with o , the final place, contains y as well, as for all places $p \in x\bullet$ holds $|p\bullet| = 1$ and, therefore, $p\bullet = \{y\}$, which implies $x \gg y$. If $y \notin (x\bullet)\bullet$, then let $t \in T$ be a transition between x and y , i.e., $x F^+ t$ and $t F^+ y$. For all places $p \in \bullet t$ holds $|p\bullet| = 1$. Thus, $p\bullet = \{t\}$. Consequently, for any two markings M_1, M_2 with $(N, M_1)[\sigma](N, M_2)$, $(N, M_1)[t]$, and not $(N, M_2)[t]$ we know that $t \in \sigma$. Starting with the transitions in $(x\bullet)\bullet$, therefore, all transitions on $\pi_N(x, y)$ have to be fired once they have been enabled in order to empty the place(s) of their pre set. Due to soundness of the system, there is a firing sequence to the final marking for all reachable markings that enable x . Consequently, firing of x implies firing of y , which yields $x \gg y$.
- The argument for the case of forwards paths can be turned around. That is, if $y \in (x\bullet)\bullet$ then every firing sequence σ containing y and ending with o , the final place, contains x as well, as for all places $p \in x\bullet$ holds $|\bullet p| = 1$ and, therefore, $\bullet p = \{x\}$, which implies $y \gg x$. If $y \notin (x\bullet)\bullet$, again, there is a transition $t \in T$ with $x F^+ t$ and $t F^+ y$. For all places $p \in t\bullet$ holds $|\bullet p| = 1$. Thus, $\bullet p = \{t\}$. Let $M_1 \in [N, M_i]$ be a marking with $M_1(p) > 1$. Due to $\bullet p = \{t\}$ and soundness of the system, there has to be a marking M_2 from which we reach M_1 via firing of t , i.e., $(N, M_2)[t](N, M_1)$. Starting with the transitions in $\bullet(\bullet y)$, therefore, all transitions on $\pi_N(x, y)$ have to be fired in order to mark the place(s) of their post set and eventually enable transition y . Again, soundness of the system guarantees that for all reachable markings, there is a firing sequence to the final marking, such that firing of y implies firing of x , which yields $y \gg x$. \square

The co-occurrence relation is derived as follows.

Proposition 2. Let $\mathcal{T}_N = (\Omega, \chi, t, b)$ be the WF-tree and $\alpha, \beta \in \Omega$ two trivial fragments, $\alpha \neq \beta$. Let $\gamma = lca(\alpha, \beta)$, $\Pi = \pi_{\mathcal{T}}\{\gamma, \beta\}$, and $\forall \omega \in \Pi [t(\omega) \neq R]$. Then, $\alpha_{\triangleleft} \gg \beta_{\triangleleft}$, iff for all $\omega \in (\Pi \setminus \{\beta\})$ one of the following conditions holds:

1. $t(\omega) = P$,
2. $t(\omega) = B$ and $b(\omega) = B_{\diamond}$, or
3. $t(\omega) = B$, $b(\omega) = L$, and with $\Theta = \{\vartheta \in \chi(\omega) \mid \ell(\vartheta) \implies\}$ it holds $\forall \vartheta \in \Theta [\beta \in \chi^+(\vartheta)]$.

Proof. Let \mathcal{T}_N , α , β , γ , Π be defined as above, (N, M_i) the respective WF-system, and $\forall \omega \in \Pi [t(\omega) \neq R]$. For both directions of the proof, let $\delta = \rho(\beta)$ and $\eta = \rho(\delta)$ be the parents of β and δ . Note that we know $t(\delta) = P$ and $t(\eta) \notin \{R, T\}$.

- \Rightarrow Let $\alpha_{\triangleleft} \gg \beta_{\triangleleft}$ and assume that there is an $\omega \in (\Pi \setminus \{\beta\})$ with $t(\omega) \neq P$ or $b(\omega) \neq B_{\diamond}$ or if $b(\omega) = L$ then it holds $\exists \vartheta \in \Theta [\beta \notin \chi^+(\vartheta)]$ with $\Theta = \{\vartheta \in \chi(\omega) \mid \ell(\vartheta) \implies\}$. For all $\omega \in (\Pi \setminus \{\beta\})$, we know $t(\omega) \neq R$ and $t(\omega) \neq T$ (as $\beta \in \chi^+(\omega)$). We first consider the LCA, i.e., fragment γ . Let

$\epsilon \in \chi(\gamma)$ with $\alpha \in \chi^+(\epsilon)$ be the child fragment of γ that contains α (it holds $\epsilon \neq \delta$). We distinguish two cases.

- (1) γ_{\triangleleft} is a transition. Then, $t(\gamma) \in \{P, B\}$, while $t(\gamma) = B$ requires $b(\gamma) = B_{\circ}$.
- (2) γ_{\triangleleft} is a place. Then, $t(\gamma) \in \{P, B\}$, while $t(\gamma) = B$ requires $b(\gamma) \in \{B_{\circ}, L\}$.

We distinguish two cases (I) $b(\gamma) = B_{\circ}$ and (II) $b(\gamma) = L$.

(I) Let $M_1, M_2 \in [N, M_i]$ be two markings with $M_1(\gamma_{\triangleleft}) > 1$ and $M_2(\gamma_{\triangleright}) > 1$. Let σ_1, σ_2 be two firing sequences with $(N, M_1)[\sigma_1](N, M_2)[\sigma_2](N, M_o)$, such that σ_2 does not contain any transition that is part of γ . As fragment ϵ represents a path from γ_{\triangleleft} to γ_{\triangleright} , σ_1 might contain only transitions that are part of ϵ . Then, it holds $\alpha_{\triangleleft} \in \sigma_1$. Since $\alpha_{\triangleleft} \gg \beta_{\triangleleft}$, also $\beta_{\triangleleft} \in \sigma_1$ (as $\beta_{\triangleleft} \notin \sigma_2$). Therefore, $\beta \in \chi^+(\epsilon)$, such that we arrive at a contradiction with the definition of $\gamma = lca(\alpha, \beta)$.

(II) Let $M_1, M_2 \in [N, M_i]$ be two markings as defined for the previous case with $M_1(\gamma_{\triangleleft}) > 1$ and $M_2(\gamma_{\triangleright}) > 1$. Consider the case of ϵ having forward orientation, $\ell(\epsilon) = \Rightarrow$. Then, there are two firing sequences σ_1, σ_2 with $(N, M_1)[\sigma_1](N, M_2)[\sigma_2](N, M_o)$, such that σ_1 contains only transitions that are part of ϵ , whereas σ_2 does not contain any transition that is part of γ . Then, α_{\triangleleft} might be part of σ_1 . As $\beta_{\triangleleft} \notin \sigma_2$, but $\alpha_{\triangleleft} \gg \beta_{\triangleleft}$, we conclude $\beta_{\triangleleft} \in \sigma_1$. Thus, $\beta \in \chi^+(\epsilon)$, again, we arrived at a contradiction with the definition of $\gamma = lca(\alpha, \beta)$. Consider the case of ϵ having backward orientation, $\ell(\epsilon) = \Leftarrow$. Then, there is a firing sequence σ_3 with $(N, M_1)[\sigma_1](N, M_2)[\sigma_3](N, M_1)[\sigma_1](N, M_2)[\sigma_2](N, M_o)$, such that σ_3 contains solely transitions that are part of ϵ . Again, α_{\triangleleft} can be part of σ_3 . From $\beta_{\triangleleft} \notin \sigma_2$ but $\alpha_{\triangleleft} \gg \beta_{\triangleleft}$, it follows $\beta_{\triangleleft} \in \sigma_1$ or $\beta_{\triangleleft} \in \sigma_3$. The latter would imply $\beta \in \chi^+(\epsilon)$ (a contradiction as above), which leads to $\beta_{\triangleleft} \in \sigma_1$. In order to ensure $\alpha_{\triangleleft} \gg \beta_{\triangleleft}$, every firing sequence σ_1 has to contain β_{\triangleleft} . Therefore, all children of fragment γ that represent paths from γ_{\triangleleft} to γ_{\triangleright} , i.e., children with forward orientation, have to contain β . As β can only be contained in one child of fragment γ , there is actually only child with forward orientation.

We summarise that $b(\gamma) \neq B_{\circ}$, while $b(\gamma) = L$ implies that $\forall \vartheta \in \Theta [\beta \in \chi^+(\vartheta)]$ with $\Theta = \{ \vartheta \in \chi(\gamma) \mid \ell(\vartheta) = \Rightarrow \}$.

For both cases, γ_{\triangleleft} being a transition or a place, we see that fragment γ does not satisfy the assumptions on a fragment $\omega \in (II \setminus \{\beta\})$ as stated above. We now consider two cases, $\eta = \gamma$ or γ is an ancestor of η . Due to $t(\delta) = P$, the former yields a contradiction, as $II \setminus \{\beta\} = \{\gamma, \delta\}$ and both fragments do not satisfy our assumption. For γ being an ancestor for η , there is a fragment κ , such that $\kappa \in \chi(\gamma)$ and $\eta \in \chi^+(\kappa)$. Again, we distinguish two cases.

- (1) κ_{\triangleleft} is a transition. Then, $t(\kappa) \in \{P, B\}$, while $t(\kappa) = B$ requires $b(\kappa) = B_{\circ}$.
- (2) κ_{\triangleleft} is a place. Now, we distinguish the three possible types of fragments for γ .

- (A) If $t(\gamma) = P$, without loss of generality, we assume γ_{\triangleleft} and γ_{\triangleright} to be places (the single places of their post-set or pre-set, respectively, would be taken if γ_{\triangleleft} or γ_{\triangleright} would be a transition). Let $M_1, M_2 \in [N, M_i]$ be two markings with $M_1(\gamma_{\triangleleft}) > 1$ and $M_2(\gamma_{\triangleright}) > 1$. Let σ_1, σ_2 be two firing sequences with $(N, M_1)[\sigma_1](N, M_2)[\sigma_2](N, M_o)$, such that σ_2 does not contain any transition that is part of γ . Due to $t(\gamma) = P$, either $\kappa_{\triangleright} F^+ \epsilon_{\triangleleft}$ and $\epsilon_{\triangleright} F^+ \kappa_{\triangleleft}$, or vice versa. In both cases, $\alpha_{\triangleleft} \gg \beta_{\triangleleft}$ requires that a firing sequence σ_3 between two markings $M_3, M_4 \in [N, M_i]$ with $M_3(\kappa_{\triangleleft}) > 1$ and $M_4(\kappa_{\triangleright}) > 1$ contains $beta_{\triangleleft}$. That is due to firing sequences leading from M_1 to M_3 , or from M_4 to M_2 that contains no transition of fragment κ , but transition α_{\triangleleft} .
- (B) If $b(\gamma) = L$, we know that $\forall \vartheta \in \Theta [\beta \in \chi^+(\vartheta)]$ with $\Theta = \{ \vartheta \in \chi(\gamma) \mid \ell(\vartheta) \implies \}$. As β can only be contained in one child of fragment γ , i.e., fragment κ , we know that $\ell(\kappa) \implies$ and, in turn, $\ell(\epsilon) \Leftarrow$. With M_1, M_2, σ_1 , and σ_2 as defined for the previous case, there might be firing sequences σ_4, σ_5 with $(N, M_1)[\sigma_1](N, M_2)[\sigma_4(N, M_1)[\sigma_5(N, M_2)[\sigma_2](N, M_o)$, such that σ_4 contains α_{\triangleleft} . Since $\alpha_{\triangleleft} \gg \beta_{\triangleleft}$, firing sequence σ_1 or σ_5 must contain β_{\triangleleft} . As in the previous case, it follows that any firing sequence σ_3 between two markings $M_3, M_4 \in [N, M_i]$ with $M_3(\kappa_{\triangleleft}) > 1$ and $M_4(\kappa_{\triangleright}) > 1$ must contain $beta_{\triangleleft}$.
- (C) If $b(\gamma) = B_{\circ}$, then ϵ_{\triangleleft} and κ_{\triangleleft} are places in the post-set of transition γ_{\triangleleft} (γ is a transition bordered bond). Let $M_5, M_6, M_7 \in [N, M_i]$ be markings with $M_5(\kappa_{\triangleleft}) > 1$, $M_5(\epsilon_{\triangleleft}) > 1$, $M_6(\kappa_{\triangleleft}) > 1$, $M_6(\epsilon_{\triangleright}) > 1$, $M_7(\kappa_{\triangleright}) > 1$, $M_7(\epsilon_{\triangleright}) > 1$. Then any firing sequence from M_5 to M_6 might contain α_{\triangleleft} . Since $\alpha_{\triangleleft} \gg \beta_{\triangleleft}$, again, all firing sequences from M_6 to M_7 must contain β_{\triangleleft} .

For all three possible types of fragments for γ , we summarise that we have to ensure that any firing sequence leading from a marking that marks κ_{\triangleleft} to a marking that marks κ_{\triangleright} must contain transition β_{\triangleleft} . Thus, for κ_{\triangleleft} being a place, we know that $b(\kappa) \neq B_{\circ}$, while $b(\kappa) = L$ implies that $\forall \vartheta \in \Theta [\beta \in \chi^+(\vartheta)]$ with $\Theta = \{ \vartheta \in \chi(\kappa) \mid \ell(\vartheta) \implies \}$ (cf., the argument for case 2, if ϵ would be an arbitrary child of κ).

For both cases, κ_{\triangleleft} being a transition or a place, fragment κ does not satisfy the assumptions on a fragment $\omega \in (\Pi \setminus \{ \beta \})$ stated above. As this argument can be applied to all fragments on the path $\pi_{\mathcal{T}}(\kappa, \eta)$, we arrive at a contradiction with our assumption.

\Leftarrow Let $\forall \omega \in (\Pi \setminus \{ \beta \})$ either $t(\omega) = P$ or $b(\omega) = B_{\circ}$, or if $(b(\omega) = L$ then $\forall \vartheta \in (\chi(\omega) \cap \Pi) [\ell(\vartheta) \implies])$ with $\Theta = \{ \vartheta \in \chi(\omega) \mid \ell(\vartheta) \implies \}$. Assume $\alpha_{\triangleleft} \gg \beta_{\triangleleft}$. With δ as defined above, one path $\pi_N(\delta_{\triangleleft}, \beta_{\triangleleft})$ is forwards conflict-free, i.e., $\delta_{\triangleleft} \gg \beta_{\triangleleft}$ according to Lemma 3. Regarding fragment η , we distinguish two cases.

- (1) η_{\triangleleft} is a transition. Then, $t(\eta) \in \{ P, B \}$, while $t(\eta) = B$ requires $b(\eta) = B_{\circ}$. Both imply that one path $\pi_N(\eta_{\triangleleft}, \delta_{\triangleleft})$ is forwards conflict-free, i.e., $\eta_{\triangleleft} \gg \delta_{\triangleleft}$. With $\delta_{\triangleleft} \gg \beta_{\triangleleft}$ we also get $\eta_{\triangleleft} \gg \beta_{\triangleleft}$.

- (2) η_{\triangleleft} is a place. Then, $t(\eta) \in \{P, B\}$, while $t(\eta) = B$ requires $b(\eta) = L$. For $t(\eta) = P$, we get $t \gg \delta_{\triangleleft}$ for all $t \in \bullet\eta_{\triangleleft}$. For $t(\eta) = B$, we have $b(\eta) = L$ and $\forall \vartheta \in \Theta [\beta \in \chi^+(\vartheta)]$ with $\Theta = \{\vartheta \in \chi(\eta) \mid \ell(\vartheta) \implies\}$. As only one child of fragment η can contain fragment β , i.e., fragment δ , we know $|\Theta| = 1$. That is, there is only one path from η_{\triangleleft} to η_{\triangleright} , represented by fragment δ . Therefore, $t \gg \delta_{\triangleleft}$ for all $t \in \bullet\eta_{\triangleleft}$. For both cases, $t(\eta) = P$ or $t(\eta) = B$, it also holds $t \gg \beta_{\triangleleft}$ for all $t \in \bullet\eta_{\triangleleft}$, since $\delta_{\triangleleft} \gg \beta_{\triangleleft}$.

We summarize that for both cases 1 and 2, we derive either $\eta_{\triangleleft} \gg \beta_{\triangleleft}$, or $t \gg \beta_{\triangleleft}$ for all $t \in \bullet\eta_{\triangleleft}$, respectively. Applying this argument to all fragments on the path $\pi_{\mathcal{T}}(\gamma, \eta)$ yields $\gamma_{\triangleleft} \gg \beta_{\triangleleft}$ or $t \gg \beta_{\triangleleft}$ for all $t \in \bullet\gamma_{\triangleleft}$, respectively. Trivially, $\alpha_{\triangleleft} \gg \gamma_{\triangleleft}$ if γ_{\triangleleft} is a transition or $\alpha_{\triangleleft} \gg t$ for all $t \in \bullet\gamma_{\triangleleft}$ if γ_{\triangleleft} is a place, due to γ being an ancestor of α . Thus, $\alpha_{\triangleleft} \gg \beta_{\triangleleft}$, which is a contradiction with our assumption of $\alpha_{\triangleleft} \not\gg \beta_{\triangleleft}$. \square

We illustrate both propositions using our example from Fig. 4(a). For instance, transitions B and E are in strict order, $B \rightsquigarrow E$, as the LCA of the trivial fragments that have B and E as entries is the polygon fragment $P2$, cf., Fig. 4(b) and Fig. 6. Here, the *order* value for the child fragment of $P2$ containing B is lower than the one for the child fragment that contains E , while the path from the root of the tree $P1$ to $P2$, i.e., $\pi_{\mathcal{T}}(P1, P2)$, does not contain any loop fragment. It also holds $D + E$ for transitions D and E due to the LCA being fragment $B3$ in Fig. 4(b) or $B_{\circ}1$ in Fig. 6, respectively. The fragment $B_{\circ}1$ is a place bordered bond and, again, the path $\pi_{\mathcal{T}}(P1, B_{\circ}1)$ does not contain any loop fragments. Transitions B and C , in turn, are an example for observation concurrency, $B \parallel C$, as their LCA is fragment $B2$ in Fig. 4(b). This fragment corresponds to the loop type fragment $L1$ in Fig. 6. Derivation of the co-occurrence is illustrated using transitions B and C . We see that the path from the respective LCA (i.e., $B2$ in Fig. 4(b), $L1$ in Fig. 6) to the trivial fragments having B and C as entries contains solely polygon fragments ($P4$ and $P5$, respectively). However, the LCA itself is a loop fragment, such that the orientation of its child fragments $P4$ and $P5$ needs to be considered. There is only one child with forward orientation, namely $P4$. It contains transition B . Therefore, we derive $C \gg B$, but $B \not\gg C$ according to Proposition 2.

Using these propositions, computation of the causal behavioural profile for a pair of transitions in a sound free-choice WF-system is very efficient.

Corollary 2. *The following problem can be solved in linear time.*

Given a sound free-choice WF-system (N, M_i) and its WF-tree \mathcal{T}_N , to compute the causal behavioural profile for a pair of transitions (a, b) if b is not contained in any rigid fragment.

Proof. Let a and b be two transitions and β be a trivial fragment of \mathcal{T}_N with $b \in \beta_{\triangleleft}$. Each of the behavioural relations, cf., propositions 1 and 2, requires analysis of fragments on a subpath from the root of \mathcal{T}_N to β . The analysis of a single fragment is performed in constant time. In the worst case, the length of the subpath is linear in size to the number of fragments in \mathcal{T}_N . Finally, the

number of fragments in \mathcal{T}_N is linear to the number of flow relations in the WF-system [20,26,27]. \square

5.2 Computation for Rigid Fragments

Given the WF-tree, the computation of the causal behavioural profile for two transitions a and b of a WF-system as introduced above assumes that there is no rigid fragment on the path from the root of the tree to b . If b is part of a rigid fragment, derivation of the behavioural relations is more costly.

In [12], we introduced a computation of the (non-causal) behavioural profile for all transitions in $O(n^3)$ time for sound free-choice WF-systems with n as the number of nodes. This approach, however, has the drawback that the behavioural profile cannot be calculated for a single pair of transitions, but solely for the Cartesian product of transitions leading to increased computational complexity. For the problem of this paper, this implies computational overhead as various transitions are irrelevant for consistency analysis. Not in all cases, such irrelevant transitions might be removed in a pre-processing step without changing semantics.

While for the behavioural profile computation in polynomial time complexity is possible for sound free-choice WF-systems, the co-occurrence relation of the causal behavioural profile imposes serious challenges. In the following, we show how this relation can be derived efficiently for three subclasses, namely sound workflow T- and S-systems, and sound free-choice WF-systems that are acyclic.

Lemma 4. *For a sound workflow T-system holds, all pairs of transitions are in the co-occurrence relation.*

Proof. Let (N, M_i) be a sound workflow T-system. Let $i \bullet = \{t_i\}$ be the initial transition (there is only one due to the structure of T-systems). For any transition $t \in T$ any path $\pi_N(t_i, t)$ is forwards conflict-free. Thus, $t_i \gg t$ (Lemma 3). Consequently, all firing sequences starting with t_i imply the occurrence of every $t \in T$. Due to soundness, such firing sequences lead to the final marking M_o . Thus, all firing sequences σ with $(N, M_i)[\sigma](N, M_o)$ contain all transitions $t \in T$. \square

Regarding our example in Fig. 4(a), we see that Lemma 4 suffices to derive the co-occurrence relation for all pairs of transitions that can not be treated according to Proposition 2 introduced before as they are part of a rigid fragment. The subnet represented by fragment $R1$ in Fig. 4(b) and Fig. 6 is a T-Net, such that all transitions inside are pairwise co-occurring (e.g., $F \gg J$ and $J \gg F$). This knowledge, in turn, is also used to derive co-occurrence for pairs of transitions, in which one transition is outside the rigid. For instance, we already know $D \gg K$, as the trivial fragment having transition K as entry is directly contained in fragment $P1$ (Proposition 2 can be applied to decide co-occurrence for D and K). However, K is also the exit of the rigid fragment $R1$, such that it is co-occurring to all transitions inside the $R1$. Thus, it follows that also D is co-occurring to all these transitions, e.g., $D \gg H$.

For sound workflow S-systems, the co-occurrence relation can be traced back to the notion of dominators and post-dominators known from graph theory. For

a WF-net $N = (P, T, F)$, i and o as its initial and final place, and two nodes $x, y \in X$, x is a dominator of y , iff for all paths $\pi_N(i, y)$ it holds $x \in \pi_N(i, y)$. x is a post-dominator of y , iff for all paths $\pi_N(y, o)$ it holds $x \in \pi_N(y, o)$.

Lemma 5. *For two transitions x and y of a sound workflow S-system holds, $x \gg y$, iff y is dominator or post-dominator of x .*

Proof. Let (N, M_i) be a sound workflow S-system and $x, y \in T$ two transitions. In a workflow S-system, every reachable marking $M \in [N, M_i)$ marks exactly one place, as only i is marked initially and for all transitions $t \in T$ we know $|\bullet t| = 1 = |t \bullet|$. Therefore, for every firing sequence $\sigma = t_1, \dots, t_n$ we know that there is a path $\pi_N(t_1, t_n)$ containing all transitions of σ in the respective order.

\Rightarrow Let y be a dominator or a post-dominator of x and assume $x \not\gg y$. If y is a dominator of x , then $y \in \pi_N(i, x)$ for every path $\pi_N(i, x)$. Thus, any firing sequence σ with $(N, M_i)[\sigma](N, M_1)$ with $(N, M_1)[x]$ is required to contain y , i.e., $x \gg y$. If y is a post-dominator of x , the argument can be turned around for all paths $\pi_N(x, o)$.

\Leftarrow Let $x \gg y$ and assume that y is neither a dominator nor a post-dominator of x . $x \gg y$ implies that any firing sequence σ with $x \in \sigma$ and $(N, M_i)[\sigma](N, M_o)$ contains y as well. Thus, all paths $\pi_N(i, o)$ that contain x also contain y , i.e., y is a dominator (if $y F^+ x$) or post-dominator (if $x F^+ y$) of x . \square

For the more generic case of sound free-choice WF-systems that are acyclic, the co-occurrence relation can be traced back to the exclusiveness relation. Note that it is easy to see that two transitions that are exclusive to each other are not co-occurring. Therefore, this case is not considered in the following lemma.

Lemma 6. *In a sound free-choice WF-system holds, two transitions x and y that are not exclusive ($x \not\bowtie y$), while y is not part of a control flow cycle ($y \not\mathcal{P}^{\neq} y$) are co-occurring, if and only if, all transitions exclusive to y are exclusive to x .*

Proof. Let (N, M_i) be a sound WF-system and $x, y \in T$ two transitions with $x \not\bowtie y$, and $y \not\mathcal{P}^{\neq} y$. We need the following implications for free-choice sound WF-systems that have been proved in [12].

- Strict order $x \rightsquigarrow y$ implies $x F^+ y$ and $x \mathcal{P}^{\neq} y$.
 - Reverse strict order $x \rightsquigarrow^{-1} y$ implies $y F^+ x$ and $y \mathcal{P}^{\neq} x$.
 - Observation concurrency $x || y$ implies either $y F^+ x$ and $x F^+ y$, or there is a marking reachable from the initial marking that enables both transitions.
- (\Leftarrow) Let $t + y \Rightarrow t + x$ for all transitions $t \in T$ and assume $x \not\gg y$. The relations of the behavioural profile partition the set $T \times T$. As we also know $x \not\bowtie y$ we distinguish three cases of how x and y might be related according to the profile.

($x \rightsquigarrow y$) We know $x F^+ y$ and $x \mathcal{P}^{\neq} y$, such that there is a path $\pi_N(x, y)$.

If any path $\pi_N(x, y)$ is forwards conflict-free, this yields $x \gg y$ according to Lemma 3, a contradiction with our assumption. If there is no path $\pi_N(x, y)$ that is forwards conflict-free, there is a $p \in P$ with $p \in \pi_N(x, y)$ for some $\pi_N(x, y)$, such that $|p \bullet| > 1$. If $y \in p \bullet$, we know that there

is another transition $t_y \in p\bullet$ with $t_y + y$ due to free-choiceness of the net and $y \not\prec^{\times} y$. From $x F^+ t_y$, we get $x \not\prec t_y$ (cf., Lemma 3 in [12]), a contradiction. If $y \notin p\bullet$, let $t_1 \in p\bullet$ be a transition. We know $x F^+ t_1$ and, therefore, $x \not\prec t_1$. As $y + t_1$ would imply $x + t_1$, we derive $y \not\prec t_1$. Thus, it holds either $t_1 \rightsquigarrow y$, $t_1 \rightsquigarrow^{-1} y$, or $t_1 \parallel y$.

$(t_1 \rightsquigarrow^{-1} y)$ We know $y F^+ t_1$ and $t_1 \not\prec^{\times} y$. As p is in $\pi_N(x, y)$, we have $p F^+ y$. Thus, there must be a transition $t_2 \in p\bullet$ with $t_2 F^+ y$. From $y F^+ t_1$, we get $y F^+ p_1$ for some $p_1 \in \bullet t_1$. Due to the free-choiceness of the net, t_1 and t_2 share all places in their preset, such that also $p_1 F^+ y$, which yields a contradiction with $y \not\prec^{\times} y$.

$(t_1 \parallel y)$ We know either $y F^+ t_1$ and $t_1 F^+ y$, or there is a marking that enables both y and t_1 . The former is not in line with the assumption of $y \not\prec^{\times} y$. The latter is not possible either: let $(N, M)[y]$ and $(N, M)[t_1]$ for some $M \in [N, M_i]$. Due to $p F^+ y$ either also $p \in \bullet y$ or the path implies a firing sequence $(N, M)[\sigma](N, M_2)$ (property of sound free-choice systems), such that all places of the preset of y are marked at least twice. In both cases, the safeness property that holds for sound free-choice systems would be violated.

Therefore, it holds $t_1 \rightsquigarrow y$ for all $t_1 \in p\bullet$ for some $p \in P$ and $\pi_N(x, y)$ with $p \in \pi_N(x, y)$ and $|p\bullet| > 1$. Thus, it also holds $t_1 F^+ y$ and $y \not\prec^{\times} t_1$ for all these transitions t_1 . Now, either one path $\pi_N(t_1, y)$ is forwards conflict-free, which yields $t_1 \gg y$ according to Lemma 3, or there is a place $p_2 \in P$ with $p_2 \in \pi_N(t_1, y)$ for some $\pi_N(t_1, y)$, such that $|p_2\bullet| > 1$. In this case, the argument for p can be applied recursively for p_2 , as for all transitions $t_2 \in p_2\bullet$ it holds $t_2 F^+ y$. Note that the recursive step is only initiated, if the respective place has not been visited before (which might be the case due to control flow cycles). Consequently, we arrive at $t_1 \gg y$ for all transitions $t_1 \in p\bullet$ for some $p \in P$ and $\pi_N(x, y)$ with $p \in \pi_N(x, y)$ and $|p\bullet| > 1$. Therefore, we deduce $x \gg y$, a contradiction.

$(x \rightsquigarrow^{-1} y)$ For the sake of completeness, we show how the argument for the previous case of $x \rightsquigarrow y$ is turned around for this case. From $x \rightsquigarrow^{-1} y$ we know $y F^+ x$ and $x \not\prec^{\times} y$, such that there is a path $\pi_N(y, x)$. If any path $\pi_N(y, x)$ is backwards conflict-free, this yields $x \gg y$ according to Lemma 3, a contradiction with our assumption. If there is no path $\pi_N(y, x)$ that is backwards conflict-free, there is a $p \in P$ with $p \in \pi_N(y, x)$ for some $\pi_N(y, x)$, such that $|\bullet p| > 1$. If $y \in \bullet p$, we know that there is another transition $t_y \in \bullet p$ with $t_y + y$ due to free-choiceness of the net and $y \not\prec^{\times} y$. From $t_y F^+ x$, we get $t_y \not\prec x$ (cf., Lemma 3 in [12]), a contradiction. If $y \notin \bullet p$, let $t_1 \in \bullet p$ be a transition. We know $t_1 F^+ x$ and, therefore, $t_1 \not\prec x$. As $t_1 + y$ would imply $t_1 + x$, we derive $t_1 \not\prec y$. Thus, it holds either $y \rightsquigarrow t_1$, $y \rightsquigarrow^{-1} t_1$, or $y \parallel t_1$.

$(y \rightsquigarrow^{-1} t_1)$ We know $t_1 F^+ y$ and $y \not\prec^{\times} t_1$. As p is in $\pi_N(y, x)$, we have $y F^+ p$. From $t_1 F^+ y$, we know that there must be a place $p_2 \in t_1\bullet$ with $p_2 F^+ y$. As $p = p_2$ would lead to a contradiction with $y \not\prec^{\times} y$, it holds $p \neq p_2$. For the same reason, we have $p \not\prec^{\times} y$ and $p \not\prec^{\times} p_2$. From

$p_2 F^+ y$ and $y F^+ p$ we get $p_2 F^+ p$. Assume a marking $M \in [N, M_i]$ that is reached via firing of t_1 , i.e., $M(p) > 0$ and $M(p_2) > 0$. Due to the free-choiceness and soundness of the net, the path $\pi_N(p_2, p)$ implies the existence of a respective firing sequence. As $p \not\mathcal{F}^* y$ and $p \not\mathcal{F}^* p_2$, this firing sequence can lead to a marking $M_2 \in [N, M_i]$ with $M(p_2) > 1$, a contradiction with the safeness property of sound free-choice WF-systems.

$(t_1 || y)$ We know either $y F^+ t_1$ and $t_1 F^+ y$, or there is a marking that enables both y and t_1 . The former is not in line with the assumption of $y \not\mathcal{F}^* y$. The latter is not possible either: let $(N, M)[y]$ and $(N, M)[t_1]$ for some $M \in [N, M_i]$. Due to $y F^+ p$ either also $y \in \bullet p$ or the path implies a firing sequence $(N, M)[\sigma](N, M_2)$ (property of sound free-choice systems), such that the place p is marked at least twice. In both cases, the safeness property that holds for sound free-choice systems would be violated.

Therefore, it holds $y \rightsquigarrow t_1$ for all $t_1 \in \bullet p$ for some $p \in P$ and $\pi_N(y, x)$ with $p \in \pi_N(y, x)$ and $|\bullet p| > 1$. Thus, it also holds $y F^+ t_1$ and $t_1 \not\mathcal{F}^* y$ for all these transitions t_1 . Now, either one path $\pi_N(y, t_1)$ is backwards conflict-free, which yields $t_1 \gg y$ according to Lemma 3, or there is a place $p_2 \in P$ with $p_2 \in \pi_N(y, t_1)$ for some $\pi_N(y, t_1)$, such that $|\bullet p_2| > 1$. In this case, the argument for p can be applied recursively for p_2 , as for all transitions $t_2 \in \bullet p_2$ it holds $y F^+ t_1$. Note that the recursive step is only initiated, if the respective place has not been visited before (which might be the case due to control flow cycles). Consequently, we arrive at $t_1 \gg y$ for all transitions $t_1 \in \bullet p$ for some $p \in P$ and $\pi_N(y, x)$ with $p \in \pi_N(y, x)$ and $|\bullet p| > 1$. Therefore, we deduce $x \gg y$, a contradiction.

$(x || y)$ We know either $x F^+ y$ and $y F^+ x$, or there is a marking that enables both x and y . Again, the former is not in line with the assumption of $y \not\mathcal{F}^* y$. Now, we consider two cases, whether or nor there is a path $\pi_N(i, y)$ that is forwards conflict-free. If so, it holds $i \gg y$, i.e., all firing sequences starting in M_i and leading to M_o contain transition y , such that the assumption of $x \not\gg y$ is violated. If not, there is a $p \in P$ with $p \in \pi_N(i, y)$ for some $\pi_N(i, y)$, such that $|p \bullet| > 1$. For such a place p , we prove two properties.

1. If $p F^+ x$, then for all $t_1 \in p \bullet$ it holds $t_1 \not\mathcal{F}^* y \Rightarrow t_1 \not\mathcal{F}^* x$. Assume that this implication does not hold, i.e., there is a $t_1 \in p \bullet$ with $t_1 \not\mathcal{F}^* y$ and $t_1 F^+ x$. From $p F^+ y$ we know that there must be a $t_2 \in p \bullet$ with $t_2 = y$ or $t_2 F^+ y$. The former leads to $t_1 + y$ due to $y \not\mathcal{F}^* y$. Therefore, it holds $t_1 + x$, yielding a contradiction with $t_1 F^+ x$. In case of $t_2 F^+ y$, we know $y \not\mathcal{F}^* p$ from $y \not\mathcal{F}^* y$. Further on, $y \not\mathcal{F}^* p$ implies $y \not\mathcal{F}^* t_1$. Thus, either $y + t_1$ or $y || t_1$. The latter implies the existence of a marking $M \in [N, M_i]$ with $(N, M)[y]$ and $(N, M)[t_1]$. Due to $p F^+ y$ this would violate the safeness property of sound free-choice systems. Thus, $y + t_1$ and, therefore, $x + t_1$, a contradiction with $t_1 F^+ x$.

2. If $p \not\mathcal{F}^{\times} x$, then for all $t_1 \in p\bullet$ it holds $t_1 F^+ y$. Assume that this is not the case, i.e., there is a $t_1 \in p\bullet$ with $t_1 \not\mathcal{F}^{\times} y$. From $y \mathcal{F}^{\times} y$ we get $y \mathcal{F}^{\times} p$ and, therefore, $y \mathcal{F}^{\times} t_1$. As for the previous property, $y||t_1$ would violate safeness of the system. Thus, $y + t_1$. From $p \mathcal{F}^{\times} x$, we get $t_1 \mathcal{F}^{\times} x$, while $x \mathcal{F}^{\times} t_1$ holds as well in order to satisfy $x \mathcal{F}^{\times} y$. Thus, either $t_1 + x$ or $t_1||x$. There is a marking $M \in [N, M_i)$ with $(N, M)[y]$ and $(N, M)[x]$, hence, there is also a marking $M \in [N, M_i)$ with $(N, M)[t_1]$ and $(N, M)[x]$, as $p F^+ y$ and $t_1 \in p\bullet$. Thus, it holds $t_1||x$, which yields a contradiction as $t_1 + y$ requires $t_1 + x$.

Based thereon, we conclude the following for all conflicts that might lead to y not being part of a firing sequence starting in M_i and leading to M_o . That is, we consider all places p on a path $\pi_N(i, y)$ with $|p\bullet| > 1$. If $p F^+ x$, the first property ensures that if y will not be part of the firing sequence due to firing of $t_1 \in p\bullet$ with $t_1 \not\mathcal{F}^{\times} y$, x cannot be part either, that is, $t_1 \mathcal{F}^{\times} x$ holds true. We also know that x and y are enabled concurrently in some marking. Thus, once there is a conflict at place p on a path $\pi_N(i, y)$ and $p \mathcal{F}^{\times} x$, it has to be ensured that y is fired eventually. Here, the second property guarantees $t_1 F^+ y$ for all $t_1 \in p\bullet$. That, in turn, implies $t_2 \gg t_1$ for all $t_2 \in \bullet p$ and, as the property holds for all respective places p , also $t_2 \gg y$. Consequently, it holds $x \gg y$, a contradiction with our assumption.

- (\Rightarrow) Let $x \gg y$ and assume that there is a transition $t \in T$ with $t + y$ and $t \not\mathcal{F}^{\times} x$. Due to $t \not\mathcal{F}^{\times} x$, there is a firing sequence σ with $(N, M_i)[\sigma](N, M_o)$ that contains both transitions, t and x . From $x \gg y$, we know that also $y \in \sigma$. Thus, $x, y, t \in \sigma$ is a contradiction with the assumption of $t + y$. \square

Based thereon, computation of the causal behavioural profile can be done efficiently for sound workflow T- and S-systems and sound free-choice WF-systems that are acyclic.

Corollary 3. *The following problem can be solved in $O(n^3)$ time with n as the number of nodes of the system. For a sound WF-system that is a T- or S-system, or free-choice and acyclic, to compute the causal behavioural profile for a pair of transitions.*

Proof. Given any sound free-choice WF-system, the relations of the behavioural profile can be computed in $O(n^3)$ time [12] (T- and S-systems are free-choice). The co-occurrence relation for the causal profile is set directly in case of a T-system (cf., Lemma 4). In case of an S-system, dominators and post-dominators are determined in linear time [29]. Based thereon, co-occurrence is decided based on Lemma 5. For the case of acyclic free-choice WF-systems, co-occurrence is traced back to exclusiveness according to Lemma 6. That requires an iteration over the Cartesian product of transitions, while for each pair all other transitions are analysed, which yields a time complexity of $O(n^3)$. Thus, overall time complexity is $O(n^3)$ with n as the number of nodes of the system. \square

5.3 Implementation & Experimental Results

In order to validate our approach of deriving behavioural characteristics, we implemented the computation of the causal behavioural profiles based on WF-trees and conducted an experiment using the SAP reference model [30]. This reference model describes the functionality of the SAP R/3 system and comprises 737 EPC models. From these models, we selected those that are non-trivial (more than one element), syntactically correct, free of deadlocks or livelocks (cf., [31]), and have unambiguous instantiation semantics (cf., [32]). We also normalised multiple start and end events, and replaced OR-split and OR-join connectors with AND connectors (which does not impact on the behavioural profile, but on the causal behavioural profile). For 493 EPC models, these pre-processing steps led to a model that could be transformed into a sound free-choice WF-system following on common EPC formalisations (eg., [8]).

In our experiment, we computed the (non-causal and causal) behavioural profiles for all transitions of all 493 WF-systems separately. We grouped the models according to their size, i.e., the number of EPC nodes (the WF-systems are larger in size). Fig. 8 shows the average computation time for each model group in three experiment runs. First, we

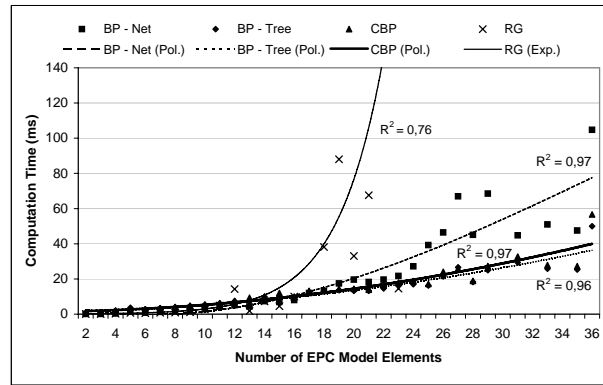

computed the behavioural profile using the approach introduced in [12] (BP-Net). Second, we derived the same profile using the WF-trees as introduced in this paper (BP-Tree). Third, we computed the causal behavioural profile (including co-occurrence) using WF-trees (CBP). Note that two WF-systems contained a rigid fragment. Both could be mapped to an S-system and, therefore, be handled as introduced in Section 5.2. To illustrate the extent to which the models of our collection suffer from the state explosion problem [33], Fig. 8 also shows the average computation time for a naive creation of the reachability graph (RG). While all reachability graphs are finite (due to soundness of the WF-systems), computation takes up to tens of seconds. For all four computations, Fig. 8 also depicts the polynomial (or exponential for RG) least squares regression.

We see that the usage of WF-trees as introduced in this paper, speeds up the computation of the behavioural profile significantly compared to the existing approach. In addition, the overhead that results from our extension of the behavioural profile yielding the causal behavioural profile is negligible. Moreover, any trace equivalence based consistency metric would have to explore the state space and, therefore, deal with the same computational complexity as

the creation of the reachability graphs. Despite the availability of state space reduction techniques, this issue it seems questionable, whether such a metric could be applied for real-world process models.

6 Related Work

Clearly, our work relates to other behavioural models that have been defined for Petri nets. While we discussed causal behavioural profiles in the light of relations proposed for workflow mining [14], the well-known concurrency relation [15], and Petri net unfoldings [16,17] already in Section 3.3, their relation to common notions of behavioural equivalence deserves further explanation.

When applied in the context of model refinement and adaptation, the multitude of equivalence criteria from the linear time – branching time spectrum [34,5,35] has three major drawbacks. First and foremost, these notions yield a true or false answer, which has been criticised in [36]. Such notions cannot be applied to assess the amount of potential behavioural deviation. Second, it is well-known that interleaving equivalences are not invariant under *forgetful refinements* of activities [37], i.e., projection of activities. However, our initial example showed that projections are a substantial part of refining and adapting a process model towards a workflow model. These phenomena, in turn, can be quantified using the causal behavioural profile. Moreover, the large body of work on equivalence-preserving refinements for Petri nets, refer to [38] for a thorough survey, illustrates that common notions of equivalence are preserved solely under a dedicated set of refinement operators. Similarly, work on net morphisms [39] and behaviour inheritance [40,41] that any extension of a net has to be done in a structured manner in order to preserve common equivalences. Third, notions of behavioural equivalence are exponential in computation, which precludes an application for large scale industrial process models. As discussed in Section 3.3, our consistency notion based on causal behavioural profiles is weaker than trace equivalence in order to compensate for computational efficiency.

Further on, the degree to which causal behavioural profiles of two related Petri nets are preserved can be used as a behavioural similarity measure. Therefore, work on causal footprints as a behavioural abstraction for determining the similarity between process models [42] or on a trace-based similarity metric for process mining [36] is also related. Refer to [43] for further pointers to notions of behavioural similarity.

Related work also includes further applications of the tree-based decomposition for behavioural models. For instance, such techniques have been applied for model transformation [19], process comparison [44], or model abstraction [21].

7 Conclusions

In this paper, we have addressed the problem of finding a behavioural consistency notion that is weaker than existing notions of behavioural equivalence, but can be computed efficiently. Our contribution is the definition of a causal behavioural

profile that captures essential behavioural characteristics of a process. Further on, we showed the efficient computation of these profile for sound free-choice workflow systems using structural decomposition techniques under the assumption that unstructured net fragments are acyclic or can be traced back to S- or T-nets. Note that this assumption still allows the system to be cyclic, either in a structured way (bond loop fragment) or in an unstructured way (rigid fragment that is a cyclic S-net). We demonstrated the efficiency by presenting experimental results from a prototypical implementation. The low polynomial complexity of our algorithms opens reasoning on behavioural consistency to industrial applications where trace equivalence does not scale.

In future research, we aim at techniques for computing causal behavioural profiles for a broader class of behavioural models, that is, systems that do not meet our assumptions on free-choiceness, soundness, and the characteristics of rigid fragments. We also want to exploit further applications of the WF-trees. While we addressed the suitability of our consistency metric in a recent survey, further empirical investigations on the human perception of behavioural consistency are needed and will be tackled in future work.

References

1. Davies, I., Green, P., Rosemann, M., Indulska, M., Gallo, S.: How do practitioners use conceptual modeling in practice? *Data Knowl. Eng.* **58**(3) (2006) 358–380
2. Nejati, S., Sabetzadeh, M., Chechik, M., Easterbrook, S.M., Zave, P.: Matching and merging of statecharts specifications. In: *ICSE, IEEE CS* (2007) 54–64
3. Dijkman, R., Dumas, M., García-Bauelos, L., Kääriky, R.: Aligning business process models. In: *EDOC, IEEE CS* (2009)
4. Rahm, E., Bernstein, P.A.: A survey of approaches to automatic schema matching. *VLDB Journal* **10**(4) (2001) 334–350
5. Glabbeek, R.: The Linear Time – Branching Time Spectrum I. The semantics of concrete, sequential processes. In: *Handbook of Process Algebra*. Elsevier (2001)
6. Aalst, W.: The application of Petri nets to workflow management. *Journal of Circuits, Systems, and Computers* **8**(1) (1998) 21–66
7. Lohmann, N.: A feature-complete Petri net semantics for WS-BPEL 2.0. In: *WS-FM*. Volume 4937 of LNCS. (2008) 77–91
8. Kindler, E.: On the semantics of EPCs: A framework for resolving the vicious circle. In: *BPM*. Volume 3080 of LNCS. (2004) 82–97
9. Eshuis, R., Wieringa, R.: Tool support for verifying UML activity diagrams. *IEEE Trans. Software Eng.* **30**(7) (2004) 437–447
10. Desel, J., Esparza, J.: *Free Choice Petri Nets*. Cambridge University Press (1995)
11. Aalst, W.: Verification of workflow nets. In: *ICATPN*. Volume 1248 of LNCS. (1997) 407–426
12. Weidlich, M., Mendling, J., Weske, M.: Computation of behavioural profiles of process models. Technical report, Hasso Plattner Institute (June 2009)
13. Dwyer, M.B., Avrunin, G.S., Corbett, J.C.: Property specification patterns for finite-state verification. In Ardis, M.A., Atlee, J.M., eds.: *FMSP, ACM* (1998) 7–15
14. van der Aalst, W.M.P., Weijters, T., Maruster, L.: Workflow mining: Discovering process models from event logs. *IEEE Trans. Knowl. Data Eng.* **16**(9) (2004) 1128–1142

15. Kovalyov, A., Esparza, J.: A polynomial algorithm to compute the concurrency relation of free-choice signal transition graphs. In: WODES, Edinburgh, The Institution of Electrical Engineers (1996) 1–6
16. McMillan, K.L.: A technique of state space search based on unfolding. *Formal Methods in System Design* **6**(1) (1995) 45–65
17. Esparza, J., Heljanko, K.: *Unfoldings: a partial-order approach to model checking*. Springer (2008)
18. Weidlich, M., Weske, M., Mendling, J.: Change propagation in process models using behavioural profiles. In: SCC, IEEE CS (2009)
19. Vanhatalo, J., Völzer, H., Koehler, J.: The refined process structure tree. In: BPM. Volume 5240 of LNCS. (2008) 100–115
20. Polyvyanyy, A., Vanhatalo, J., Völzer, H.: Simplified computation and generalization of the refined process structure tree. Technical Report RZ 3745, IBM (2009)
21. Polyvyanyy, A., Smirnov, S., Weske, M.: The triconnected abstraction of process models. In: BPM. Volume 5701 of LNCS. (2009) 229–244
22. Kiepuszewski, B., Hofstede, A., Aalst, W.: Fundamentals of control flow in workflows. *Acta Inf.* **39**(3) (2003) 143–209
23. Aalst, W.: Workflow verification: Finding control-flow errors using petri-net-based techniques. In: BPM. Volume 1806 of LNCS. (2000) 161–183
24. Aalst, W., Hirschall, A., Verbeek, H.: An alternative way to analyze workflow graphs. In: CAiSE. Volume 2348 of LNCS. (2002) 535–552
25. Esparza, J., Silva, M.: Circuits, handles, bridges and nets. In: *Applications and Theory of Petri Nets*. Volume 483 of LNCS. (1989) 210–242
26. Gutwenger, C., Mutzel, P.: A linear time implementation of SPQR-trees. In: *Graph Drawing*. Volume 1984 of LNCS. (2001) 77–90
27. Battista, G.D., Tamassia, R.: On-line maintenance of triconnected components with SPQR-trees. *Algorithmica* **15**(4) (1996) 302–318
28. Murata, T.: Petri nets: Properties, analysis and applications. *Proceedings of the IEEE* **77**(4) (1989) 541–580
29. Alstrup, S., Harel, D., Lauridsen, P.W., Thorup, M.: Dominators in linear time. *SIAM J. Comput.* **28**(6) (1999) 2117–2132
30. Curran, T.A., Keller, G., Ladd, A.: *SAP R/3 Business Blueprint: Understanding the Business Process Reference Model*. Prentice-Hall (1997)
31. Dongen, B., Jansen-Vullers, M., Verbeek, H., Aalst, W.: Verification of the SAP reference models using EPC reduction, state space analysis, and invariants. *Computers in Industry* **58**(6) (2007) 578–601
32. Decker, G., Mendling, J.: Process instantiation. *Data Knowl. Eng.* **68** (2009)
33. Valmari, A.: The state explosion problem. In: *Petri Nets*. Volume 1491 of LNCS., Springer (1996) 429–528
34. Pomello, L., Rozenberg, G., Simone, C.: A survey of equivalence notions for net based systems. In: *Advances in Petri Nets: The DEMON Project*. Volume 609 of LNCS., Springer (1992) 410–472
35. Hidders, J., Dumas, M., Aalst, W., Hofstede, A., Verelst, J.: When are two workflows the same? In: CATS. Volume 41 of CRPIT., ACS (2005) 3–11
36. de Medeiros, A.K.A., Aalst, W., Weijters, A.: Quantifying process equivalence based on observed behavior. *Data Knowl. Eng.* **64**(1) (2008)
37. Glabbeek, R., Goltz, U.: Refinement of actions and equivalence notions for concurrent systems. *Acta Inf.* **37**(4/5) (2001) 229–327
38. Brauer, W., Gold, R., Vogler, W.: A survey of behaviour and equivalence preserving refinements of petri nets. In: Rozenberg, G., ed.: *Applications and Theory of Petri Nets*. Volume 483 of LNCS., Springer (1989) 1–46

39. Winskel, G.: Petri nets, algebras, morphisms, and compositionality. *Inf. Comput.* **72**(3) (1987) 197–238
40. Basten, T., Aalst, W.: Inheritance of behavior. *JLAP* **47**(2) (2001) 47–145
41. Schrefl, M., Stumptner, M.: Behavior-consistent specialization of object life cycles. *ACM Trans. Softw. Eng. Methodol.* **11**(1) (2002) 92–148
42. Dongen, B., Dijkman, R.M., Mendling, J.: Measuring similarity between business process models. In: *CAiSE*. Volume 5074 of LNCS., Springer (2008) 450–464
43. Dumas, M., García-Bañuelos, L., Dijkman, R.M.: Similarity search of business process models. *IEEE Data Eng. Bull.* **32**(3) (2009) 23–28
44. Küster, J., Gerth, C., Förster, A., Engels, G.: Detecting and resolving process model differences in the absence of a change log. In: *BPM*. Volume 5240 of LNCS. (2008) 244–260